

General Fan Information

Centrifugal Fans are air moving devices in which the air flow is perpendicular to the shaft on which the impeller wheel is mounted. The impeller wheel is mounted in a scroll-type housing, which is required to develop the rated pressures. All fans offered in this catalog use impeller wheels with forward inclined blades with respect to the direction of rotation.

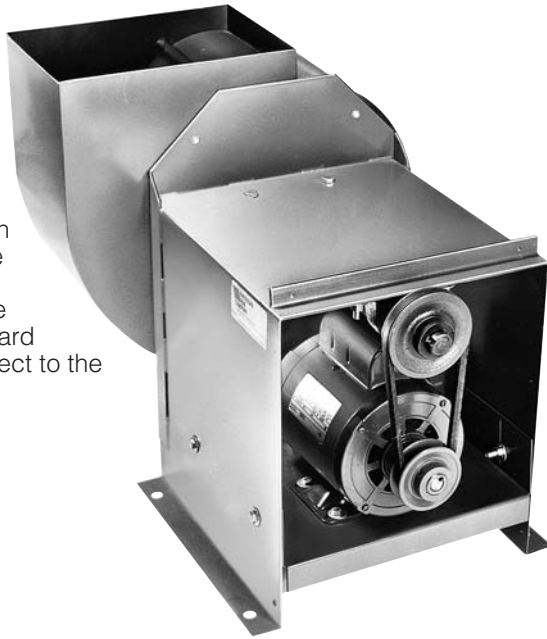

Rear view of fan
with weather cover removed

Forward Inclined Blade Fans have small, curved blades with the tips inclined in the direction of rotation.



Front view of fan
with weather cover in place

All fans have rubber mounted, dynamically balanced impeller wheels. The rugged, welded housings and integrated weather covers have a chemical resistant, synthetic resin finish. V-belts are oil resistant and static conductive. Fans are rated in accordance with AMCA. Vibration isolators are provided with all fans.

Fans are shipped in the vertical upblast discharge position, with clockwise rotation as illustrated. However, when specified, they can be factory assembled and shipped in any of seven (7) other clockwise rotation discharge positions.

Catalog Number Explanation

HFS-1310-T1

Fan Type

HFS = Hood Fan Steel Housing

Inlet Size

09 = 9"
10 = 10"
13 = 13¹/₄"
14 = 14¹/₂"

Motor Phase – Voltage

1 = Single-Phase – 115/208-230 VAC
3 = Three-Phase – 208-230/406 VAC

Motor Type

T = Totally Enclosed
E = Explosion Proof *

Motor Horsepower

02 = 1/4 HP **05** = 1/2 HP **10** = 1 HP **20** = 2 HP
03 = 1/3 HP **07** = 3/4 HP **15** = 1 1/2 HP

* Fans with explosion proof motors include spark-proof housing and impeller wheel construction.

General Fan Information

Exhaust System Recommendations

1. Mount exhaust fans on the roof so that the ducting leading to the fan inlet is under negative static pressure. If exhaust fans are mounted inside the building, all ducting connected to the fan outlet will be under positive static pressure, and if any leaks should develop in the portion of the duct inside the building, hazardous and/or toxic fumes can be forced out of the duct into that area of the building.
2. To obtain the lowest practical noise level in the exhaust system, we suggest the following measures when there is no conflict with other requirements of the system:
 - a. Use vibration isolators for mounting the exhaust fan assembly.
 - b. Select an exhaust fan that will deliver the desired CFM and static pressure with the lowest practical impeller wheel RPM. If possible, use a duct size large enough to keep duct velocities under 1800 FPM velocity.
 - c. Use a flexible connection at the fan inlet to isolate mechanical transmission of noise via the ducting between the hood and the exhaust fan.
 - d. Design the exhaust duct system with the fewest possible elbows or other fittings. Use radius type elbows and avoid square elbows. Use gradual, tapered transitions where transitions are necessary, and avoid abrupt changes in configuration or cross sectional area.
3. When ordering an exhaust fan, specify the orientation of discharge desired. Vertical upblast discharge is most common and will be supplied unless otherwise specified.
4. Fans used for hood exhaust at altitudes above 1000 ft. may require a correction factor to provide the desired CFM and static pressure. Consult the factory for additional information relating to your specific application.

How To Select a Fume Hood Exhaust Fan using the Fan Recommendation Charts

1. Find the hood type and size in the charts on the next two pages and note the recommended duct size.
2. Determine the length of the duct from the top of the fume hood to the location of fan where it will be mounted. Be sure to include all horizontal runs as well as vertical runs.
3. Determine the number of 90 degree elbows required.
4. Refer to Chart A to determine the equivalent length of straight duct resistance for each elbow.

Note, the values in Chart A are based on elbows with a turning radius of 1.5 times the duct diameter. Elbows with a smaller turning radius should not be used as they have larger static pressure losses and create more noise.
5. Multiply the equivalent straight duct length from Chart A by the number of elbows used and add it to the overall duct length to determine the equivalent length of duct for the system.
6. Use that length (rounded up the the next larger size) to find the recommended fan from the chart.
7. Select the required motor type to finish the catalog number.

T1 = Totally enclosed–Single-phase
T3 = Totally enclosed–Three- phase
E1 = Explosion Proof–Single-phase
E3 = Explosion Proof–Three- phase

Chart A

Duct Size	Equivalent Straight Duct Resistance
8"	15 feet
10"	20 feet
12"	25 feet
14"	30 feet
16"	36 feet
18"	41 feet
20"	46 feet

Example:

The recommended fan with a Totally enclosed, Single-phase motor for the hood and duct system shown in the sketch to the right would be as follows:

1. Recommended duct size = **12"**
2. Length of duct 26' + 7' = **33'**
3. Number of elbows = **1**
4. 1 elbow x 25' = **25'**
5. Straight duct 33'
Elbow equivalent +25' = **58'**
6. Recommended fan for 6 foot H05 Fume Hood and equivalent of 75' of duct **HFS-1007**
7. with Totally enclosed – Single-Phase motor **HFS-1007-T1**

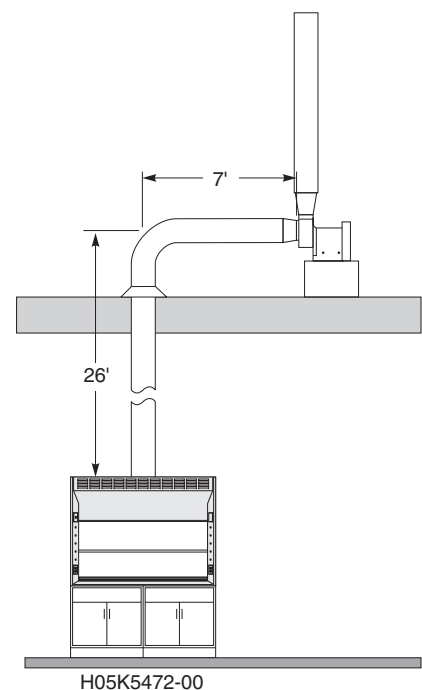

Fan Recommendation Charts

Equivalent Length in Straight Duct			25 Feet		50 Feet		75 Feet		100 Feet		150 Feet	
Hood Size	CFM	Duct Size	Total S.P.	Fan Model Number	Total S.P.	Fan Model Number	Total S.P.	Fan Model Number	Total S.P.	Fan Model Number	Total S.P.	Fan Model Number
LV05 High Performance/Low Constant Volume Bench Hood												
4 ft	520	12	1/4	HFS-0902	1/4	HFS-0902	1/4	HFS-0902	1/4	HFS-0902	1/4	HFS-0902
5 ft	670	12	1/4	HFS-0902	1/4	HFS-0902	3/8	HFS-0902	3/8	HFS-0902	3/8	HFS-0902
6 ft	830	12	3/8	HFS-0902	3/8	HFS-0902	3/8	HFS-0902	1/2	HFS-0903	1/2	HFS-0903
7 ft	990	14	1/4	HFS-0903	1/4	HFS-0903	3/8	HFS-0903	3/8	HFS-0903	3/8	HFS-0903
8 ft	1150	14	1/4	HFS-0905	3/8	HFS-0905	3/8	HFS-0905	3/8	HFS-0905	1/2	HFS-0905
H05 General Purpose Bench Hood												
4 ft	810	12"	1/4	HFS-0902	3/8	HFS-0902	3/8	HFS-0902	3/8	HFS-0902	1/2	HFS-0903
5 ft	1050	12"	3/8	HFS-0903	1/2	HFS-0905	1/2	HFS-0905	5/8	HFS-0905	3/4	HFS-0905
6 ft	1290	12"	1/2	HFS-1007	5/8	HFS-1007	3/4	HFS-1007	3/4	HFS-1007	1	HFS-1007
8 ft	1770	14"	1/2	HFS-1310	1/2	HFS-1310	5/8	HFS-1310	5/8	HFS-1310	7/8	HFS-1310
H07 Combination Sash Bench Hood												
4 ft	480	12	1/4	HFS-0902	1/4	HFS-0902	1/4	HFS-0902	1/4	HFS-0902	1/4	HFS-0902
5 ft	630	12	1/4	HFS-0902	1/4	HFS-0902	1/4	HFS-0902	1/4	HFS-0902	1/4	HFS-0902
6 ft	780	12	1/4	HFS-0902	1/4	HFS-0902	3/8	HFS-0902	3/8	HFS-0902	3/8	HFS-0902
8 ft	1090	12	1/4	HFS-0903	3/8	HFS-0903	1/2	HFS-0905	1/2	HFS-0905	5/8	HFS-0905
H08 ADA Bench Hood												
4 ft	610	12	1/4	HFS-0902	1/4	HFS-0902	1/4	HFS-0902	1/4	HFS-0902	1/4	HFS-0902
5 ft	790	12	1/4	HFS-0902	1/4	HFS-0902	3/8	HFS-0902	3/8	HFS-0902	3/8	HFS-0902
6 ft	980	12	3/8	HFS-0903	3/8	HFS-0903	1/2	HFS-0905	1/2	HFS-0905	5/8	HFS-0905
H09 ADA Combination Sash Bench Hood												
4 ft	480	12	1/4	HFS-0902	1/4	HFS-0902	1/4	HFS-0902	1/4	HFS-0902	1/4	HFS-0902
5 ft	630	12	1/4	HFS-0902	1/4	HFS-0902	1/4	HFS-0902	1/4	HFS-0902	1/4	HFS-0902
6 ft	780	12	1/4	HFS-0902	1/4	HFS-0902	3/8	HFS-0902	3/8	HFS-0902	3/8	HFS-0902
H10 Split Sash Bench Hood												
8 ft	1770	14	1/2	HFS-1310	1/2	HFS-1310	5/8	HFS-1310	5/8	HFS-1310	7/8	HFS-1310
10 ft	2260	16	1/2	HFS-1310	5/8	HFS-1310	5/8	HFS-1310	5/8	HFS-1310	3/4	HFS-1310
12 ft	2740	16	5/8	HFS-1315	3/4	HFS-1315	7/8	HFS-1315	7/8	HFS-1315	1 1/8	HFS-1315
H20 Isotope Bench Hood												
4 ft	980	12	3/8	HFS-0903	1/2	HFS-0905	1/2	HFS-0905	1/2	HFS-0905	5/8	HFS-0905
5 ft	1260	12	1/2	HFS-1007	5/8	HFS-1007	3/4	HFS-1007	3/4	HFS-1007	1	HFS-1007
6 ft	1550	12	3/4	HFS-1310	7/8	HFS-1310	1 1/8	HFS-1310	1 1/8	HFS-1310	1 3/8	**
8 ft	2130	14	5/8	HFS-1310	3/4	HFS-1310	1	HFS-1315	1	HFS-1315	1 1/8	HFS-1315
H25 Perchloric Acid Bench Hood												
4 ft	980	12	3/8	***	1/2	***	1/2	***	1/2	***	5/8	***
5 ft	1260	12	1/2	***	5/8	***	3/4	***	3/4	***	1	***
6 ft	1550	12	3/4	***	7/8	***	1 1/8	***	1 1/8	***	1 3/8	***
H50 Dynamic Barrier – Ultra Low Constant Volume Hood												
4 ft	225	8	1/8	HFS-0905*	1/8	HFS-0905*	1/8	HFS-0905*	1/8	HFS-0905*	1/4	HFS-0905*
5 ft	280	8	1/8	HFS-0905*	1/8	HFS-0905*	1/4	HFS-0905*	1/4	HFS-0905*	1/4	HFS-0905*
6 ft	350	8	1/4	HFS-0905*	1/4	HFS-0905*	1/4	HFS-0905*	3/8	HFS-0905*	1/2	HFS-0905*
8 ft	485	8	1/4	HFS-0905*	3/8	HFS-0905*	3/8	HFS-0905*	5/8	HFS-0905*	3/4	HFS-0905*

* Use a duct air by-pass at fan to increase the amount of air handled by fan.

** Standard fan not available, consult your Kewaunee sales representative.

*** Requires a Perchloric Acid exhaust fan, consult your Kewaunee sales representative.

Fan Recommendation Charts

Equivalent Length in Straight Duct			25 Feet		50 Feet		75 Feet		100 Feet		150 Feet	
Hood Size	CFM	Duct Size	Total S.P.	Fan Model Number	Total S.P.	Fan Model Number	Total S.P.	Fan Model Number	Total S.P.	Fan Model Number	Total S.P.	Fan Model Number
HOP HOPEC General Purpose Bench Hood												
4 ft	400	12	1/4	HFS-0902	1/4	HFS-0902	1/4	HFS-0902	1/4	HFS-0902	1/4	HFS-0902
5 ft	540	12	1/4	HFS-0902	1/4	HFS-0902	1/4	HFS-0902	1/4	HFS-0905	1/4	HFS-0902
6 ft	680	12	1/4	HFS-0902	1/4	HFS-0902	3/8	HFS-0902	3/8	HFS-0902	3/8	HFS-0902
8 ft	950	14	1/4	HFS-0903	3/8	HFS-0903	1/2	HFS-0903	1/2	HFS-0903	5/8	HFS-0905
H70 Horizontal Sash Bench Hood												
4 ft	520	12	1/4	HFS-0902	1/4	HFS-0902	1/4	HFS-0902	1/4	HFS-0902	1/4	HFS-0902
5 ft	680	12	1/4	HFS-0902	1/4	HFS-0902	1/4	HFS-0902	1/4	HFS-0902	3/8	HFS-0902
6 ft	850	12	1/4	HFS-0902	1/4	HFS-0902	3/8	HFS-0902	3/8	HFS-0902	1/2	HFS-0903
8 ft	1180	12	3/8	HFS-0905	3/8	HFS-0905	1/2	HFS-0905	5/8	HFS-0905	3/4	HFS-0905
H30 General Purpose Walk-in Hood												
4 ft	810	12	1/4	HFS-0902	3/8	HFS-0902	3/8	HFS-0902	3/8	HFS-0902	1/2	HFS-0903
5 ft	1050	12	3/8	HFS-0903	1/2	HFS-0905	1/2	HFS-0905	5/8	HFS-0905	3/4	HFS-0905
6 ft	1290	12	1/2	HFS-1007	5/8	HFS-1007	3/4	HFS-1007	3/4	HFS-1007	1	HFS-1007
8 ft	1770	14	1/2	HFS-1310	1/2	HFS-1310	5/8	HFS-1310	5/8	HFS-1310	7/8	HFS-1310
H32 Combination Sash Walk-in Hood												
4 ft	480	12	1/4	HFS-0902	1/4	HFS-0902	1/4	HFS-0902	1/4	HFS-0902	1/4	HFS-0902
5 ft	630	12	1/4	HFS-0902	1/4	HFS-0902	1/4	HFS-0902	1/4	HFS-0902	1/4	HFS-0902
6 ft	780	12	1/4	HFS-0902	1/4	HFS-0902	3/8	HFS-0902	3/8	HFS-0902	3/8	HFS-0902
8 ft	1090	12	1/4	HFS-0903	3/8	HFS-0903	1/2	HFS-0905	1/2	HFS-0905	5/8	HFS-0905
H34 Horizontal Sash Walk-in Hood												
6 ft	2210	16	5/8	HFS-1310	3/4	HFS-1310	3/4	HFS-1310	7/8	HFS-1310	7/8	HFS-1310
8 ft	3070	18	7/8	HFS-1420	7/8	HFS-1420	7/8	HFS-1420	1	HFS-1420	1 1/8	HFS-1420
10 ft	3930	20	1 1/4	**	1 1/4	**	1 1/4	**	1 3/8	**	1 1/2	**
H36 Distillation Hood												
4 ft	1160	12	1/2	HFS-0905	5/8	HFS-0905	3/4	HFS-0905	3/4	HFS-0905	7/8	HFS-1007
5 ft	1510	12	3/4	HFS-1310	7/8	HFS-1310	1	HFS-1310	1 1/8	HFS-1310	1 3/8	**
6 ft	1860	12	1	HFS-1310	1 1/4	HFS-1315	1 3/8	HFS-1315	1 5/8	HFS-1315	1 7/8	**
8 ft	2550	16	3/4	HFS-1315	3/4	HFS-1315	7/8	HFS-1315	7/8	HFS-1315	1 1/8	HFS-1315
H52 Dynamic Barrier – Ultra Low Constant Volume Walk-in Hood												
4 ft	300	8	1/8	HFS-0905*	1/4	HFS-0905*	1/4	HFS-0905*	1/4	HFS-0905*	1/4	HFS-0905*
5 ft	400	8	1/4	HFS-0905*	3/8	HFS-0905*	3/8	HFS-0905*	1/2	HFS-0905*	5/8	HFS-0905*
6 ft	500	8	3/8	HFS-0905*	1/2	HFS-0905*	1/2	HFS-0905*	5/8	HFS-0905*	7/8	HFS-0905*
8 ft	675	10	1/4	HFS-0902*	3/8	HFS-0902*	3/8	HFS-0902*	1/2	HFS-0902*	5/8	HFS-0903*
T90 Single-sided TruView Hood												
4 ft	550	12	1/4	HFS-0902	1/4	HFS-0902	1/4	HFS-0902	1/4	HFS-0902	1/4	HFS-0902
5 ft	700	12	1/4	HFS-0902	1/4	HFS-0902	1/4	HFS-0902	1/4	HFS-0902	1/4	HFS-0902
6 ft	850	12	1/4	HFS-0902	1/4	HFS-0902	1/4	HFS-0902	1/4	HFS-0902	3/8	HFS-0902
T90 Double-sided TruView Hood												
4 ft	1100	12	1/4	HFS-0903	3/8	HFS-0905	3/8	HFS-0905	1/2	HFS-0905	5/8	HFS-0905
5 ft	1400	12	1/4	HFS-1007	3/8	HFS-1007	1/2	HFS-1007	5/8	HFS-1007	3/4	HFS-1007
6 ft	1700	14	1/4	HFS-1310	3/8	HFS-1310	3/8	HFS-1310	1/2	HFS-1310	5/8	HFS-1310

* Use a duct air by-pass at fan to increase the amount of air handled by fan.

** Standard fan not available, consult your Kewaunee sales representative.

General Fan Information

How To Select V-Belt Drive Fans (when not using the Fan Recommendation Charts)

1. Select the size fan desired from the CFM-Static Pressure charts on the next several pages, and sizing instructions below.
2. Select the type of motor desired to suit the operating conditions:
 T1 = Totally enclosed–Single-phase
 T3 = Totally enclosed–Three-phase
 E1 = Explosion Proof–Single-phase
 E3 = Explosion Proof–Three-phase
3. V-belt drive fans are provided with adjustable pitch motor sheaves to cover the RPM range indicated for each fan. If the desired RPM and/or CFM-Static Pressure is not indicated, the fan will be shipped with the adjustable motor sheave set to the midpoint of the RPM range.

Sizing a Fan

To determine the size of a fan required for a fume hood system, both the air volume flow rate and the system static pressure must be determined. The air volume flow rate at various face velocities, in cubic feet per minute (CFM), is shown on the specification page for each style and size of fume hood. The system static pressure must be calculated based on the air volume flow rate, static pressure, and duct configuration.

Below is a simplified method of calculating the system static pressure which gives sufficient accuracy for the small fan systems used for one or two laboratory fume hoods. This method ignores the effect poor inlet conditions can have on fan performance. This effect can be minimized by using at least five (5) feet of straight duct at the inlet of the fan and having a gradual transition to the fan inlet.

1. Determine Duct Size

The duct size used should be at least as large as the duct collar on the fume hood. (12" on all Supreme Air Fume Hoods.) For quiet operation, a duct velocity of less than 1800 feet per minute should be used. Duct velocities for various duct sizes and air volume flow rates are given in Table 1.

2. Determine Hood Static Pressure

The hood static pressure can be found listed next to the air volume flow rates on the specification page for each style fume hood.

3. Calculated Loss in Straight Duct

The length of straight duct should be known to within ten (10) feet of

the actual length. Small inaccuracies in the length of duct do not affect the results. The static pressure loss per hundred feet of straight duct is given in Table 2. The static pressure loss in the straight duct is equal to the length of straight duct in feet, multiplied by the value obtained from Table 2, divided by 100.

4. Calculated Loss in Elbow

The exact number of elbows needs to be determined as it has a significant effect on the results. Table 3 gives the static pressure loss per elbow. The values in Table 3 are based on elbows with a turning radius of 1.5 times the duct diameter. Elbows of smaller turning radius should not be used as they have larger static pressure losses and create more noise. The static pressure loss in the elbows is equal to the number of elbows multiplied by the value obtained from Table 3.

5. Calculate Loss in "Y"

Table 4 gives the static pressure loss for a "Y" connection used on hoods with two duct collars or duct systems serving two fume hoods. The values in Table 4 are based on "Y"s with included angles of 90 degrees. "Y"s with larger included angles and "T"s should not be used as they have larger pressure losses and create more noise.

6. Calculate Total Static Pressure

The total system static pressure is the sum of the fume hood static pressure, the static pressure loss due to friction in the straight duct, and the static pressure losses due to change in direction and

turbulence in the elbows and "Y"s. Add the values obtained in steps 2 through 5 to calculate the total system static pressure.

Table 1

CFM	Duct Velocity feet per minute				
	10"	12"	14"	16"	18"
400	733	509			
500	917	637	468		
600	1100	764	561		
700	1283	891	655	501	
800	1467	1019	748	573	
900	1650	1146	842	645	509
1000	1833	1273	935	716	566
1100	2017	1401	1029	788	622
1200	2200	1528	1123	859	679
1300	2384	1655	1216	931	736
1400	2567	1783	1310	1003	792
1500	2750	1910	1403	1074	849
1600	2934	2037	1497	1146	905
1700		2165	1590	1218	962
1800		2292	1684	1289	1019
1900		2419	1777	1361	1075
2000		2546	1871	1432	1132
2200		2801	2058	1576	1245
2400			2245	1719	1358
2600			2432	1862	1471
2800			2619	2005	1584
3000			2806	2149	1698
3200			2993	2292	1811
3400				2435	1924
3600				2578	2037
3800				2722	2150
4000				2865	2264

 = Increased noise level

General Fan Information

Sizing a Fan (Continued)

Table 2

Static Pressure Loss per 100 Ft. of Duct in Inches of Water					
CFM	10"	12"	14"	16"	18"
400	0.09	0.04			
500	0.14	0.06	0.03		
600	0.20	0.08	0.04		
700	0.27	0.11	0.05	0.03	
800	0.34	0.14	0.06	0.03	
900	0.43	0.17	0.08	0.04	0.02
1000	0.52	0.21	0.10	0.05	0.03
1100	0.63	0.25	0.12	0.06	0.03
1200	0.74	0.30	0.14	0.07	0.04
1300	0.86	0.34	0.16	0.08	0.04
1400	0.99	0.40	0.18	0.09	0.05
1500	1.13	0.45	0.21	0.11	0.06
1600	1.28	0.51	0.24	0.12	0.07
1700		0.57	0.26	0.14	0.07
1800		0.64	0.29	0.15	0.08
1900		0.71	0.33	0.17	0.09
2000		0.78	0.36	0.18	0.10
2200		0.94	0.43	0.22	0.12
2400			0.51	0.26	0.14
2600			0.59	0.30	0.17
2800			0.68	0.35	0.19
3000			0.78	0.40	0.22
3200			0.88	0.45	0.25
3400				0.50	0.28
3600				0.56	0.31
3800				0.62	0.35
4000				0.69	0.38

= Increased noise level

Table 3

Static Pressure Loss per 90 Degree Elbow* in Inches of Water					
CFM	10"	12"	14"	16"	18"
400	0.01	0.01			
500	0.02	0.01	0.01		
600	0.03	0.01	0.01		
700	0.04	0.02	0.01	0.01	
800	0.05	0.03	0.01	0.01	
900	0.07	0.03	0.02	0.01	0.01
1000	0.08	0.04	0.02	0.01	0.01
1100	0.10	0.05	0.03	0.02	0.01
1200	0.12	0.06	0.03	0.02	0.01
1300	0.14	0.07	0.04	0.02	0.01
1400	0.16	0.08	0.04	0.02	0.02
1500	0.18	0.09	0.05	0.03	0.02
1600	0.21	0.10	0.05	0.03	0.02
1700		0.11	0.06	0.04	0.02
1800		0.13	0.07	0.04	0.03
1900		0.14	0.08	0.05	0.03
2000		0.16	0.09	0.05	0.03
2200		0.19	0.10	0.06	0.04
2400			0.12	0.07	0.04
2600			0.14	0.08	0.05
2800			0.17	0.10	0.06
3000			0.19	0.11	0.07
3200			0.22	0.13	0.08
3400				0.14	0.09
3600				0.16	0.10
3800				0.18	0.11
4000				0.20	0.12

*Loss for 45 degree elbows is 1/2 that for 90 degree elbows.

Table 4

Static Pressure Loss for "Y" Fitting* in Inches of Water				
CFM	12"	14"	16"	18"
800	0.05	0.03	0.01	
900	0.07	0.03	0.01	
1000	0.09	0.04	0.02	
1100	0.10	0.05	0.02	0.01
1200	0.12	0.06	0.02	0.01
1300	0.14	0.07	0.03	0.02
1400	0.17	0.08	0.03	0.02
1500	0.19	0.09	0.04	0.02
1600	0.22	0.10	0.04	0.03
1700	0.25	0.11	0.05	0.03
1800	0.28	0.13	0.05	0.03
1900	0.31	0.14	0.06	0.04
2000	0.34	0.16	0.07	0.04
2200	0.41	0.19	0.08	0.05
2400		0.23	0.10	0.06
2600		0.26	0.11	0.07
2800		0.31	0.13	0.08
3000		0.35	0.15	0.09
3200		0.40	0.17	0.10
3400			0.19	0.11
3600			0.21	0.13
3800			0.24	0.14
4000			0.27	0.16

* Based on two 12" diameter ducts joining to the duct size shown. The included angle of the two 12" ducts is 90 degrees.

V-Belt Drive Fan – Forward Inclined Blades

Wheel Diameter: 9³/₁₆" **Inlet:** Size: 9" dia. O.D.
Area: 0.43 sq. ft. I.D. **Outlet:** Size: 10³/₄" x 6¹/₂" outside
Area: 0.468 sq. ft. inside

HFS-0902-T1		HFS-0902-T3		HFS-0902-E1		HFS-0902-E3		1/4-Horse Power Motor				
Wheel RPM	CFM@ 1/8" SP	CFM@ 1/4" SP	CFM@ 3/8" SP	CFM@ 1/2" SP	CFM@ 5/8" SP	CFM@ 3/4" SP	CFM@ 7/8" SP	CFM@ 1" SP	CFM@ 1 1/8" SP	CFM@ 1 1/4" SP	CFM@ 1 3/8" SP	CFM@ 1 1/2" SP
654	684	487	—	—	—	—	—	—	—	—	—	—
732	796	648	—	—	—	—	—	—	—	—	—	—
805	895	777	609	—	—	—	—	—	—	—	—	—
879	994	898	760	562	—	—	—	—	—	—	—	—
938	1074	986	869	720	—	—	—	—	—	—	—	—

HFS-0903-T1		HFS-0903-T3		HFS-0903-E1		HFS-0903-E3		1/3-Horse Power Motor				
Wheel RPM	CFM@ 1/8" SP	CFM@ 1/4" SP	CFM@ 3/8" SP	CFM@ 1/2" SP	CFM@ 5/8" SP	CFM@ 3/4" SP	CFM@ 7/8" SP	CFM@ 1" SP	CFM@ 1 1/8" SP	CFM@ 1 1/4" SP	CFM@ 1 3/8" SP	CFM@ 1 1/2" SP
805	895	777	609	—	—	—	—	—	—	—	—	—
879	994	898	760	562	—	—	—	—	—	—	—	—
938	1074	986	869	720	—	—	—	—	—	—	—	—
1017	1180	1101	1003	882	730	—	—	—	—	—	—	—
1085	*	*	1114	1006	884	709	—	—	—	—	—	—
1134	*	*	*	1091	981	850	—	—	—	—	—	—

HFS-0905-T1		HFS-0905-T3		HFS-0905-E1		HFS-0905-E3		1/2-Horse Power Motor				
Wheel RPM	CFM@ 1/8" SP	CFM@ 1/4" SP	CFM@ 3/8" SP	CFM@ 1/2" SP	CFM@ 5/8" SP	CFM@ 3/4" SP	CFM@ 7/8" SP	CFM@ 1" SP	CFM@ 1 1/8" SP	CFM@ 1 1/4" SP	CFM@ 1 3/8" SP	CFM@ 1 1/2" SP
1017	1180	1101	1003	882	730	—	—	—	—	—	—	—
1085	1269	1194	1114	1006	884	709	—	—	—	—	—	—
1134	1335	1260	1187	1091	981	850	—	—	—	—	—	—
1181	*	1323	1255	1169	1068	953	799	—	—	—	—	—
1245	*	*	1347	1273	1181	1081	963	796	—	—	—	—
1301	*	*	*	*	*	1184	1081	971	—	—	—	—

Wheel Diameter: 10⁵/₈" **Inlet:** Size: 10" dia. O.D.
Area: 0.53 sq. ft. I.D. **Outlet:** Size: 11³/₄" x 8" outside
Area: 0.653 sq. ft. inside

HFS-1007-T1		HFS-1007-T3		HFS-1007-E1		HFS-1007-E3		3/4-Horse Power Motor				
Wheel RPM	CFM@ 1/8" SP	CFM@ 1/4" SP	CFM@ 3/8" SP	CFM@ 1/2" SP	CFM@ 5/8" SP	CFM@ 3/4" SP	CFM@ 7/8" SP	CFM@ 1" SP	CFM@ 1 1/8" SP	CFM@ 1 1/4" SP	CFM@ 1 3/8" SP	CFM@ 1 1/2" SP
805	1235	1195	1081	928	—	—	—	—	—	—	—	—
879	1354	1327	1252	1124	979	—	—	—	—	—	—	—
938	1447	1424	1375	1267	1141	986	—	—	—	—	—	—
1017	1572	1553	1521	1450	1341	1222	1083	—	—	—	—	—
1085	1680	1662	1639	1590	1503	1397	1284	1151	—	—	—	—
1134	*	*	*	1682	1615	1516	1413	1300	1149	—	—	—

* Do not use at these static pressures. Will result in severe motor overload.

V-Belt Drive Fan – Forward Inclined Blades

Wheel Diameter: 12³/₁₆"

Inlet: Size: 13¹/₄" dia. O.D.
Area: 0.94 sq. ft. I.D.

Outlet: Size: 13¹/₄" x 9⁵/₈" outside
Area: 0.886 sq. ft. inside

HFS-1310-T1		HFS-1310-T3		HFS-1310-E1		HFS-1310-E3		1-Horse Power Motor				
Wheel RPM	CFM@ 1/8" SP	CFM@ 1/4" SP	CFM@ 3/8" SP	CFM@ 1/2" SP	CFM@ 5/8" SP	CFM@ 3/4" SP	CFM@ 7/8" SP	CFM@ 1" SP	CFM@ 1 1/8" SP	CFM@ 1 1/4" SP	CFM@ 1 3/8" SP	CFM@ 1 1/2" SP
654	1951	1739	1650	1441	985	—	—	—	—	—	—	—
732	2217	2033	1891	1824	1616	1231	—	—	—	—	—	—
805	2463	2326	2147	2062	1991	1789	1462	—	—	—	—	—
879	2718	2606	2416	2296	2239	2170	1987	1712	—	—	—	—
938	*	*	*	2508	2421	2375	2298	2115	1860	1525	—	—

HFS-1315-T1		HFS-1315-T3		HFS-1315-E1		HFS-1315-E3		1 1/2-Horse Power Motor				
Wheel RPM	CFM@ 1/8" SP	CFM@ 1/4" SP	CFM@ 3/8" SP	CFM@ 1/2" SP	CFM@ 5/8" SP	CFM@ 3/4" SP	CFM@ 7/8" SP	CFM@ 1" SP	CFM@ 1 1/8" SP	CFM@ 1 1/4" SP	CFM@ 1 3/8" SP	CFM@ 1 1/2" SP
879	2718	2606	2416	2296	2239	2170	1987	1712	—	—	—	—
938	2920	2807	2657	2508	2421	2375	2298	2115	1860	1525	—	—
980	3066	2949	2822	2657	2557	2507	2456	2344	2155	1889	—	—
1030	3234	3117	3019	2854	2738	2657	2619	2564	2436	2252	2000	1693
1080	*	*	*	3056	2916	2823	2773	2732	2672	2535	2364	2120
1130	*	*	*	*	*	*	*	2889	2847	2784	2646	2486

Wheel Diameter: 13¹/₂"

Inlet: Size: 14¹/₂" dia. O.D.
Area: 1.13 sq. ft. I.D.

Outlet: Size: 14⁵/₈" x 10³/₄" outside
Area: 1.079 sq. ft. inside

HFS-1420-T1		HFS-1420-T3		HFS-1420-E1		HFS-1420-E3		2-Horse Power Motor				
Wheel RPM	CFM@ 1/8" SP	CFM@ 1/4" SP	CFM@ 3/8" SP	CFM@ 1/2" SP	CFM@ 5/8" SP	CFM@ 3/4" SP	CFM@ 7/8" SP	CFM@ 1" SP	CFM@ 1 1/8" SP	CFM@ 1 1/4" SP	CFM@ 1 3/8" SP	CFM@ 1 1/2" SP
765	3008	2869	2708	2573	2477	2347	2108	1665	—	—	—	—
807	3187	3057	2909	2768	2668	2569	2418	2158	1696	—	—	—
861	3416	3297	3162	3017	2905	2823	2723	2583	2342	1942	—	—
905	3603	3492	3368	3232	3110	3012	2933	2828	2683	2446	2062	—
950	3794	3686	3570	3444	3317	3214	3138	3087	2946	2798	2568	2206
1020	*	*	*	*	*	*	3440	3372	3298	3205	3089	2907

* Do not use at these static pressures. Will result in severe motor overload.

Fan Dimensions

Exhaust/Auxiliary Air Fan Dimensions

HFS-0902 HFS-0903 HFS-0905 HFS-1007

HFS-1310 HFS-1315 HFS-1415 HFS-1420

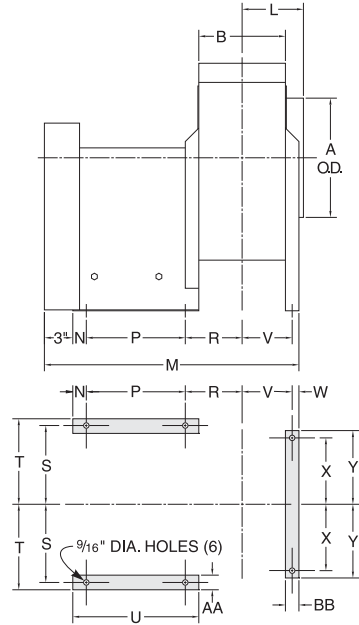
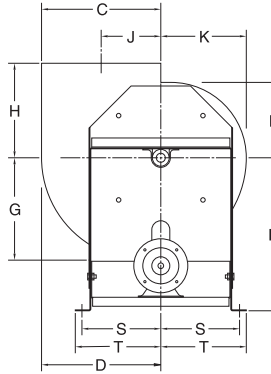
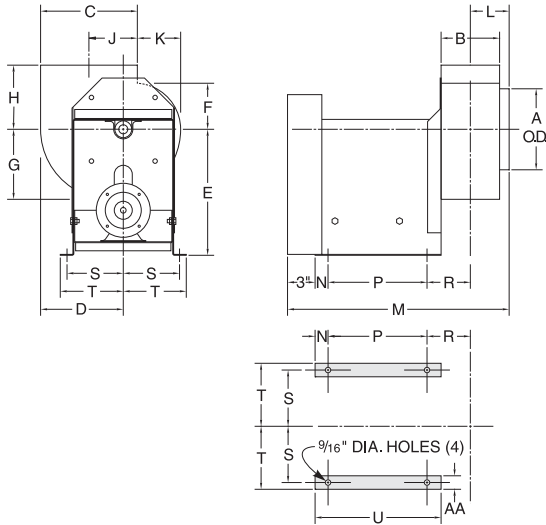

	A	B	C	D	E	F	G	H	J	K	L	M	N	P	R	S	T	U	V	W	X	Y	AA	BB
HFS-0902	9	6 ¹ / ₂	10 ³ / ₄	9 ³ / ₁₆	14	5 ¹ / ₈	7 ³ / ₄	6 ⁷ / ₈	3 ¹³ / ₁₆	6 ³ / ₈	4 ⁵ / ₁₆	24 ⁵ / ₈	11 ¹ / ₂	11	4 ¹³ / ₁₆	6 ¹ / ₄	7	14	—	—	—	—	1 ⁷ / ₈	—
HFS-0903	9	6 ¹ / ₂	10 ³ / ₄	9 ³ / ₁₆	14	5 ¹ / ₈	7 ³ / ₄	6 ⁷ / ₈	3 ¹³ / ₁₆	6 ³ / ₈	4 ⁵ / ₁₆	24 ⁵ / ₈	11 ¹ / ₂	11	4 ¹³ / ₁₆	6 ¹ / ₄	7	14	—	—	—	—	1 ⁷ / ₈	—
HFS-0905	9	6 ¹ / ₂	10 ³ / ₄	9 ³ / ₁₆	14	5 ¹ / ₈	7 ³ / ₄	6 ⁷ / ₈	3 ¹³ / ₁₆	6 ³ / ₈	4 ⁵ / ₁₆	24 ⁵ / ₈	11 ¹ / ₂	11	4 ¹³ / ₁₆	6 ¹ / ₄	7	14	—	—	—	—	1 ⁷ / ₈	—
HFS-1007	10	8	11 ³ / ₄	10 ¹¹ / ₁₆	14	6 ⁵ / ₁₆	9 ³ / ₁₆	8 ¹ / ₈	4 ¹³ / ₁₆	7 ¹¹ / ₁₆	5 ¹ / ₈	26 ⁷ / ₃₂	11 ¹ / ₂	11	5 ¹⁹ / ₃₂	7 ¹ / ₄	7 ¹³ / ₁₆	14	—	—	—	—	1 ¹ / ₂	—
HFS-1310	13 ¹ / ₄	9 ⁵ / ₈	13 ¹ / ₄	13 ¹ / ₄	17	8 ³ / ₈	11 ¹ / ₂	10 ¹ / ₂	6 ⁵ / ₈	9 ⁷ / ₈	6 ³ / ₈	28 ¹¹ / ₃₂	11 ¹ / ₂	11	6 ¹⁵ / ₃₂	8 ³ / ₄	9 ¹ / ₂	14	5 ⁵ / ₈	2 ² / ₃₂	7 ³ / ₈	8 ³ / ₁₆	1 ⁵ / ₈	1 ¹ / ₂
HFS-1315	13 ¹ / ₄	9 ⁵ / ₈	13 ¹ / ₄	13 ¹ / ₄	17	8 ³ / ₈	11 ¹ / ₂	10 ¹ / ₂	6 ⁵ / ₈	9 ⁷ / ₈	6 ³ / ₈	28 ¹¹ / ₃₂	11 ¹ / ₂	11	6 ¹⁵ / ₃₂	8 ³ / ₄	9 ¹ / ₂	14	5 ⁵ / ₈	2 ² / ₃₂	7 ³ / ₈	8 ³ / ₁₆	1 ⁵ / ₈	1 ¹ / ₂
HFS-1420	14 ¹ / ₂	10 ³ / ₄	14 ⁵ / ₈	14 ⁵ / ₈	17	9 ³ / ₈	12 ³ / ₄	11 ³ / ₈	7 ⁵ / ₁₆	11	7	29 ⁷ / ₁₆	11 ¹ / ₂	11	6 ¹⁵ / ₁₆	9 ³ / ₄	10 ¹ / ₂	14	6 ³ / ₁₆	1 ³ / ₁₆	8	8 ¹³ / ₁₆	1 ⁵ / ₈	1 ¹ / ₂

Fan Accessories

Fan Inlet and Outlet Adapters (Transition Sections)

Fan Inlet and Outlet Adapter (Transition Sections) are available for connection to all Kewaunee V-Belt drive fans. Inlet adapters are sized to connect to 12" dia. ducting from the fume hood

on one side, and the fan inlet on the other, making a rigid connection. Outlet adapters are available for connection to 12" dia. stackheads and are sized to fit over the top of the fan

outlet. The transition sections are fabricated of 20 gauge cold rolled steel, phosphate coated and have a baked chemical resistant, synthetic resin finish.

Inlet Adapter

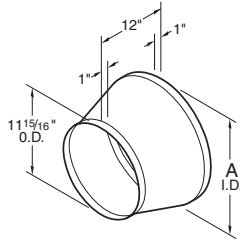

Outlet Adapter

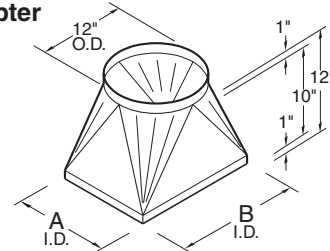

Inlet Adapter	Fan Catalog Number	Dimension A
HIA-1209-00	HFS-0902 HFS-0903 HFS-0905	9 ¹ / ₁₆ "
HIA-1210-00	HFS-1007	10 ¹ / ₁₆ "
HIA-1213-00	HFS-1310 HFS-1315	13 ⁵ / ₁₆ "
HIA-1214-00	HFS-1420	14 ⁹ / ₁₆ "

Outlet Adapter	Fan Catalog Number	Dimensions	
		A	B
HOA-0912-00	HFS-0902 HFS-0903 HFS-0905	6 ⁹ / ₁₆ "	10 ¹³ / ₁₆ "
HOA-1012-00	HFS-1007	8 ¹ / ₁₆ "	11 ¹³ / ₁₆ "
HOA-1312-00	HFS-1310 HFS-1315	9 ¹¹ / ₁₆ "	13 ⁵ / ₁₆ "
HOA-1412-00	HFS-1420	10 ¹³ / ₁₆ "	14 ¹¹ / ₁₆ "

Vertical Exhaust Duct Stackhead Assembly

Vertical Exhaust Duct Stackhead Assemblies provide rain cap protection and reduce the possibility of cross contaminating building air and/or auxiliary air intakes by directing air upward instead of downward. These assemblies have the added advantage of little or no pressure loss

through them. Each assembly consists of a vertical discharge cap and transition section that fits over the rectangular exhaust fan outlet. The parts are fabricated of cold rolled steel, phosphate coated with baked chemical resistant, synthetic resin finish, or type 316 stainless steel.

Cold Rolled Steel Stackhead	Stainless Steel Stackhead	Fan Catalog Number	Dimensions				
			A	B	C	D	E
HES-0909-00	HES-0909-0S	HFS-0902 HFS-0903 HFS-0905	6 ⁹ / ₁₆ "	10 ¹³ / ₁₆ "	20 ⁷ / ₈ "	99 ¹ / ₈ "	9"
HES-1011-00	HES-1011-0S	HFS-1007	8 ¹ / ₁₆ "	11 ¹³ / ₁₆ "	22 ¹ / ₈ "	97 ⁷ / ₈ "	11"
HES-1313-00	HES-1313-0S	HFS-1310 HFS-1315	9 ¹¹ / ₁₆ "	13 ⁵ / ₁₆ "	27 ¹ / ₂ "	92 ¹ / ₂ "	13"
HES-1414-00	HES-1414-0S	HFS-1420	10 ¹³ / ₁₆ "	14 ¹¹ / ₁₆ "	28 ³ / ₄ "	91 ¹ / ₄ "	14"

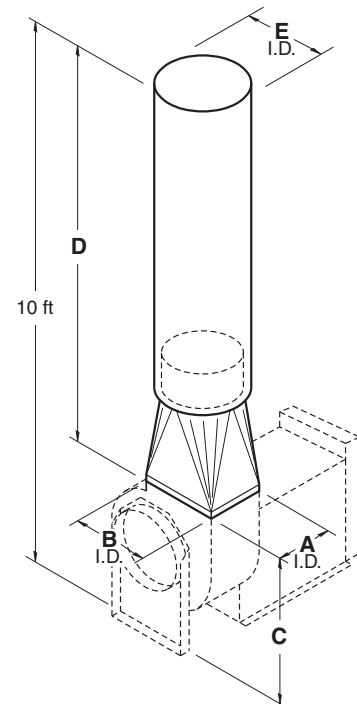

Full-Jet Spray Nozzle Assembly

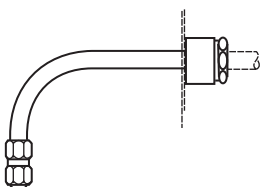

Designed for exhaust ducts on fume hood exhaust systems that need wash downs after use. Made of type 316 stainless steel, the assembly consists of a spray nozzle, piping to the centerline of the duct, and an exterior duct coupling. The nozzle is rated for 1.4 GPM at 20 psi.

- 0869-10** for 10" diameter Duct
- 0869-12** for 12" diameter Duct