

Installation Instructions

Supreme Air Fume Hood Electrical Supplement

July 1999

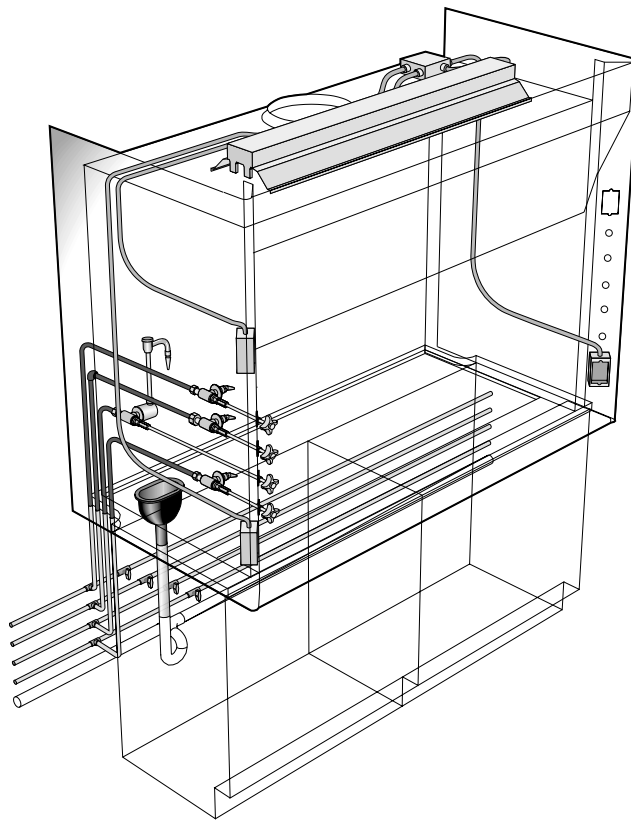

Purpose:

This supplement is provided as a guide for properly connecting and maintaining Supreme Air series fume hoods that are factory wired. A factory wired fume hood will be delivered equipped with all electrical receptacles, light fixtures and switches mounted on the fume hood and wired to an electrical junction box. The junction box is mounted on the top panel of the hood behind the top front panel.

The instructions and illustrations that follow must be followed in order to comply with the requirement set forth by Underwriters Laboratories, Inc. Any deviation from these instructions or modification of the factory wiring may void the UL listing.

If technical assistance is required please contact:

Kewaunee Scientific Corporation
Fume Hood Engineering
P.O. Box 1842
Statesville, NC 28687-1842
Phone: (704) 873-7202
Fax: (704) 872-4355

Contents:

<u>Section</u>	<u>Subject</u>
I	Technical Information
II	Installation Location Requirements
III	General Installation Instructions
IV	Fan Switch Wiring
V	Control Identification
VI	Other Connections
VII	Cleaning Instructions

I. Technical Information:

Supply Voltage: 120V AC and/or 240V AC*	Maximum Humidity Rating: 95%
Supply Current: 20 A	Maximum Fluid Pressure: 60 psi
Supply Frequency: 60Hz	Maximum Gas Pressure: 20 psi
Maximum Altitude: 2000M	Input Conductor Gauge: 12 ga.
Max. Ambient Temperature: 40°C	Input Conductor Type: THHN
	Input Conductor Temperature Rating: 90° C

**Supply voltage will be indicated on the rating plate on each junction box.*

II. Installation Location Requirements:

Mains supply fluctuations should not exceed $\pm 10\%$ of rated voltage.
Intended for connection to an Installation Category II circuit.
Intended for use in a Pollution Degree 2 environment.

III. General Installation Instructions:

Assemble and securely mount the fume hood per the instruction in the accompanying installation manual.

Preparation:

1. Locate junction boxes.
Supply circuits will be attached to the unit within each junction box. These junction boxes are located on top of the hood, behind the front panel. If the top of the fume hood is flush with or extends into the ceiling, the ceiling tiles must be removed to gain access to the junction box. If the top of the fume hood is below the ceiling level, access can be gained from above the hood, or through the ceiling enclosure panel.
2. Note the input ratings on the rating plate. Each junction box will have a rating plate for each supply circuit located above an unused knockout.

Installation:

3. Run supply conductors into junction box.
Conductors should be enclosed in conduit.
Conduit should be attached to the junction box using an appropriate bushing.
Supply should be attached to a 20 Amp circuit breaker.
Supply circuit should be dedicated to the fume hood.
4. Attach conductors to terminals.
Remove the junction box cover.
A label in the bottom of the junction box will identify each supply terminal.
Attach supply conductors to proper terminals using 16 in-lb. of torque.
5. Attach building ground to grounding lug identified by symbol. 
6. Replace the junction box cover.

IV. Fan Switch Wiring

Fan switch wiring will be located in a separate 6" x 4" junction box on top of the hood.

Note: The fan controlled by this switch should not exceed 1 HP.

1. Follow steps 1 through 3 as in the general installation instructions with the following exceptions:
The fan switch circuitry is wired for 120 VAC/20 A/60 Hz input. The input circuit to the junction box must match the requirements of the fan motor.
2. There are terminals in the junction box for output to the fan motor. A label in the box also identifies these terminals.
3. Attach the conductors as previously noted, using conduit and a bushing to insulate the conductors running from the junction box to the fan motor.
4. Install proper thermal unit in the fan switch to match the maximum motor current (load) in amps. The thermal unit is installed by removing the fan switch cover plate and mounting the thermal unit in the location specified in the diagram below.

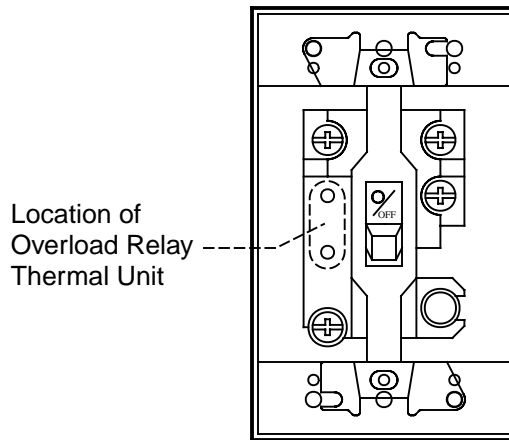

The fan switch is a Square D Manual Starter, Class 2510, Type F, and Size FHP. Thermal units can be purchased from a Square D distributor. The following chart for referencing the proper thermal unit number is reprinted from Table 43, Page 23-28, of the Square D Digest, Volume 170.

Motor Full Load Current (Amp.)	Thermal Unit Number	Motor Full Load Current (Amp.)	Thermal Unit Number	Motor Full Load Current (Amp.)	Thermal Unit Number
0.4 – 0.4	A .49	1.48 – 1.56	A 1.75	4.08 – 4.32	A 9.25
0.5 – 0.5	A .54	1.57 – 1.65	A 1.86	4.33 – 4.90	A 9.85
0.50 – 0.5	A .59	1.66 – 1.79	A 1.99	4.91 – 5.35	A 11.0
0.54 – 0.58	A .65	1.80 – 1.95	A 2.15	5.36 – 5.85	A 11.9
0.59 – 0.65	A .71	1.96 – 2.15	A 2.31	8.99 – 9.67	A 13.2
0.66 – 0.71	A .78	2.16 – 2.38	A 2.57	9.68 – 9.95	A 14.1
0.72 – 0.78	A .86	2.39 – 2.75	A 2.81	9.96 – 10.8	A 14.8
0.79 – 0.85	A .95	2.76 – 2.84	A 3.61	10.9 – 12.1	A 16.2
0.86 – 0.96	A 1.02	2.85 – 3.06	A 3.95	12.2 – 13.1	A 17.9
0.97 – 1.04	A 1.16	3.07 – 3.45	A 4.32	13.2 – 13.9	A 19.8
1.05 – 1.16	A 1.25	3.46 – 3.70	A 4.79	14.0 – 15.0	A 21.3
1.17 – 1.29	A 1.39	3.71 – 4.07	A 8.38	15.1 – 16.0	A 25.2
1.30 – 1.37	A 1.54				

V. Control Identification:

The captions for each illustration gives the Kewaunee part number, rating and general description.

Electrical Fixtures:

Use the following illustration to identify electrical fixtures:

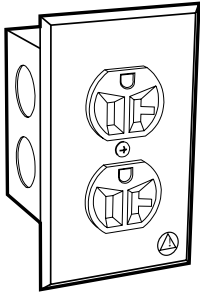

0581-1V
120V / 20A / 60Hz
Receptacle

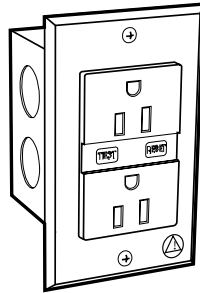

0656-1V
120V / 20A / 60Hz
GFCI Receptacle

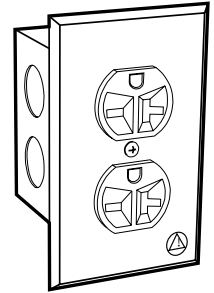

0582-1V
240V / 20A / 60Hz
Receptacle

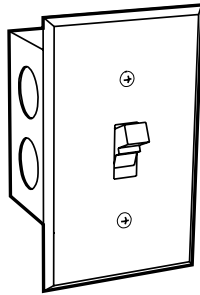

0655-1V
277V / 20A / 60Hz
Light Switch

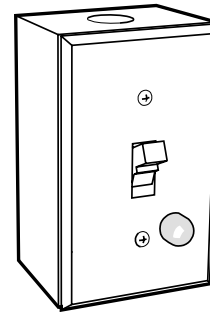

0695-1S
277V / 16A / 60Hz
Fan Switch

All voltages are AC / Total load for all circuits is 20 Amps

V. Control Identification: (cont)

Service Fittings:

There are two basic styles of service fittings: Front load and remote control. A front load fitting's valve is located immediately behind the handle, inside the fascia. A remote control fitting's valve is located immediately behind the fitting, behind the hood wall. The handle of the service fitting has a color-coded index button indicating the service. The type of service determines the valve type and the maximum pressure. See the chart below for information on individual fittings.

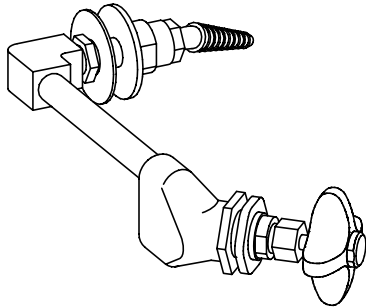

Front Load Fitting

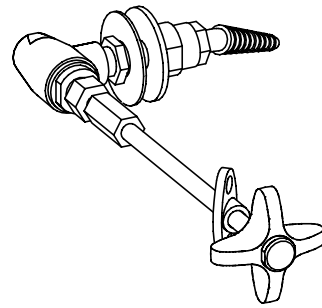

Remote Control Fitting

Symbol	Color	Service	Valve	Maximum psi
CW	Green	Cold Water	Disc	60
HW	Red	Hot Water	Disc	60
AIR	Orange	Air	Conical	60
VAC	Yellow	Vacuum	Conical	15
DW	White	Distilled Water	Disc	60
STM	Black	Steam	Disc	60
GAS	Blue	Gas	Conical	20
HYD	Light Blue	Hydrogen	Conical	60
NIT	Brown	Nitrogen	Conical	60
OXY	Light Green	Oxygen	Conical	60
N2	Brown	Nitrogen	Conical	60
IW	White	Ice Water	Disc	60
He	Black	Helium	Conical	60
Ar	Violet	Argon	Conical	60
P	Pink	Propane	Conical	20
H2S	Black	Hydrogen Sulfite	Conical	20
Nat.Gas	White	Natural Gas	Conical	20
C2H2	Violet	Acetylene	Conical	60
CO2	Pink	Carbon Dioxide	Conical	60
SO2	Tan	Sulfur Dioxide	Conical	20
CG	Light Blue	Cylinder Gas	Conical	20
BUT	Light Blue	Butane	Conical	20
NH3	Light Green	Ammonia	Conical	60

VI. Other Connections:**1. Piping Connections:****A. Pre-piped Hoods:**

Gas and steam fittings are piped using black iron, distilled water fittings are piped using PVC and all others are piped using copper tubing. Connection should be made to supply piping using an appropriate coupling or union of the same material.

B. Non-pre-piped Hoods:

Connections to supply piping should be made at the valve using the appropriate piping material and a male adapter or nipple.

2. Duct Connections:

Exhaust ductwork should be attached to the duct collar on the fume hood using screws and sealed with silicone. In the case of a stainless steel duct collar and duct material, the attachment can be made with a welded joint.

3. Drainage Connections:

Drainpipes should be connected to the threaded drain extension below the sink or cupsink using a proper coupling. This connection should be properly sealed to prevent leakage.

VII. Cleaning Instructions:

The exterior metal surface and interior liner of the fume hood should be cleaned with a non-abrasive, standard household cleaner or a mild soap and water solution. The cleaning solution should be applied to a cloth to wipe the surface. The sash glass should be cleaned with a standard household window cleaner.

Solvents or other flammable cleaners should not be used to clean the fume hood.

This supplement is provided as a guide for properly connecting and maintaining Supreme Air series fume hoods that are factory wired. A factory wired fume hood will be delivered equipped with all electrical receptacles, light fixtures and switches mounted on the fume hood and wired to an electrical junction box. The junction box is mounted on the top panel of the hood behind the top front panel.

The instructions and illustrations that follow must be followed in order to comply with the requirement set forth by Underwriters Laboratories, Inc. Any deviation from these instructions or modification of the factory wiring may void the UL listing.

If technical assistance is required please contact:

Kewaunee Scientific Corporation
Fume Hood Engineering
P.O. Box 1842
Statesville, NC 28687-1842
Phone: (704) 873-7202
Fax: (704) 872-4355

