

Supreme Air Fume Hood

Bench Hood with Vertical Rising Sash

(indicate fittings/fixtures required)

(indicate fittings/fixtures required)

Light Switch

Plugged

Plugged [Air]

Plugged [Gas]

Plugged [Cold Water]

Plugged [Vacuum] [Option F]

120VAC GFI Duplex

[Alarm Location 2] **Blank Face Plate**

[Alarm Location 1] Plugged

[Air] Plugged

[Gas] Plugged

[Cold Water] Plugged

[Option F] [Vacuum] Plugged

120VAC GFI Duplex

Liner Option: (pick one only)

- K** KMER
- G** Kemglass
- S** Type 304 St. Steel
- T** Phenolic Resin

By-Pass Option: (pick one only)

- Open By-Pass
- B** Restricted By-Pass
(restricted to 20%
of face opening)
(front panel louvers omitted)

Pre-piping: (pick one if required)

- Pre-pipe Up
- Pre-pipe Down

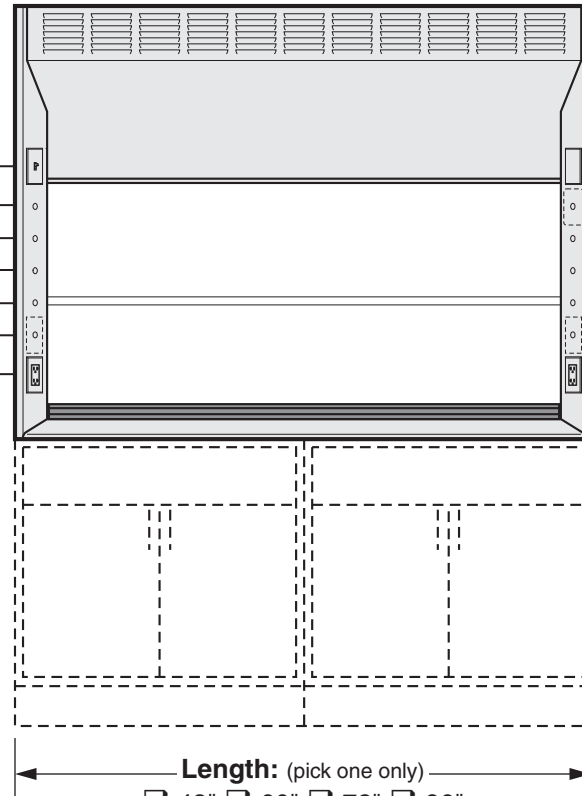

Length: (pick one only)

- 48" 60" 72" 96"

Add On Options: (indicate options required)

Interior Baffle Arrangement Options: (pick one only)

- Standard Fixed Baffle
- A** Adjustable Baffle
- C** Single-Point Adjustable Baffles

Distillation Rack Option: (pick if required)

- D** Distillation Rack

Fire Extinguisher Option: (pick if required)

- E** Fire Extinguisher

Electric and Plumbing Options: (pick all required)

- F** Two Additional G.F.I. Receptacles 120VAC
- G** Front Load Fittings
- H** Pre-Wired to Top of Hood – UL Listed

Safety Shield Option: (pick if required)

- I** Safety Shield

Interior Lighting Options: (pick one only)

- Standard Fluorescent Light (T-5 Ballast)
- J** Fluorescent Light (T-8 Ballast)
- K** Vapor Proof Light (Incandescent)
- L** Explosion Proof Light (Incandescent)

Lower Deflector Vane Options: (pick one only)

- Standard Painted Lower Deflector Vane
- O** Stainless Steel Deflector Vane

Sash Handle Options: (pick one only)

- Standard Painted Metal Sash Handle
- Q** Stainless Steel Sash Handle

Top Front Panel Options: (pick all required)

- T** Chevron Grille (Open By-Pass Only)
- V** Vision Panel

Fume Hood Alarm Options: (pick one if required)

- W** Air Alert 300 Alarm (location 1)
- Z** Air Alert 300 Alarm (location 2)
- M** Air Alert 600 Alarm (location 1)

Sash Frame and Glass Options: (pick one only)

- Standard Frameless Laminated Safety Glass Sash
- 1** Frameless Tempered Glass Sash
- 2** Framed Laminated Safety Glass Sash
- 3** Framed Tempered Glass Sash
- 4** Stainless Steel Safety Glass Sash
- 5** Stainless Steel Tempered Glass Sash

Miscellaneous Options: (pick all required)

- 6** Tissue Screen
- 7** Stainless Steel Duct Collar
- 8** Gravity Sash Stop @ 17" above deflector vane

<p style="font-size: small; margin: 0;">LINER LENGTH BY-PASS ADD-ON OPTIONS</p> <p style="font-size: large; margin: 0;">H05 <input type="checkbox"/> 54 <input type="checkbox"/> <input type="checkbox"/> <input type="checkbox"/> 00</p>	<p style="font-size: small; margin: 0;">COLOR</p>	<p style="font-size: small; margin: 0;">ITEM NO.</p>
<p style="font-size: small; margin: 0;">PROJECT NAME:</p>	<p style="font-size: small; margin: 0;">QUANTITY</p>	

Supreme Air Fume Hood

H05

Bench Hood with Vertical Rising Sash

Plan of Work Top

Indicate cutouts required by noting cupsink part number or size and/or hole type and size at desired location:

Example:

The example below calls for two 491 cupsink cutouts in the rear along with a 2" dia. vent hole.

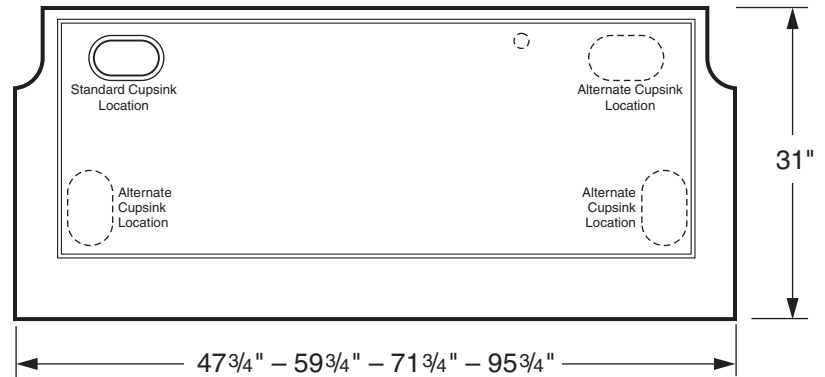
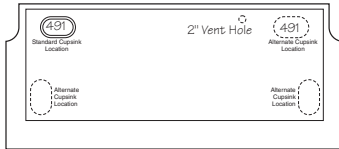

For sink or steambath cutout:
Sketch in size and location required.

If no cutout is marked, work top will ship with 3"x6" cupsink cutout in left rear corner. If no cutout is required, cross out standard cupsink location. (Cupsink is

Work Top Material

- Black Kemresin
- Type 304 Stainless Steel
- Type 316 Stainless Steel

Overall Hood Length	Sash Opening			Total CFM and Static Pressure					
	Width	Height	Total Ft. ² *	80 FPM	S.P.	100 FPM	S.P.	120 FPM	S.P.
4'-0" / 48"	40"	28"	8.1	650	0.15"	810	0.25"	980	0.35"
5'-0" / 60"	52"	28"	10.5	840	0.20"	1050	0.30"	1260	0.45"
6'-0" / 72"	64"	28"	12.9	1040	0.25"	1290	0.40"	1550	0.60"
8'-0" / 96"	88"	28"	17.7	1420	0.15"	1770	0.25"	2130	0.35"

* Includes 1" opening below deflector vane.

- CFM requirements shown above are for **Open By-Pass** hoods. The CFM requirements for a **Restricted By-Pass** hood with the sash fully open is the same as above. The by-pass opening with the sash closed is 20% of that with the sash fully open.
- Static pressures shown are for the pressure drop through the hoods only. The total pressure drop through the hood and the duct system must be calculated to select the proper exhaust fan.

Rough-In for 4' - 5' - 6' Hoods

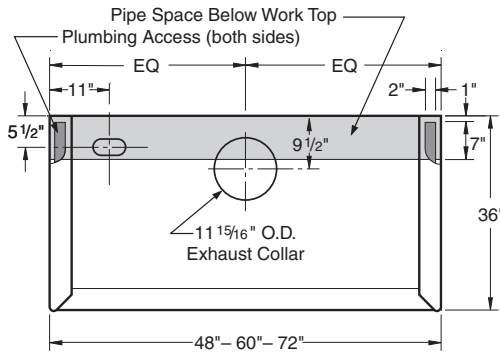

Rough-In for 8' Hoods

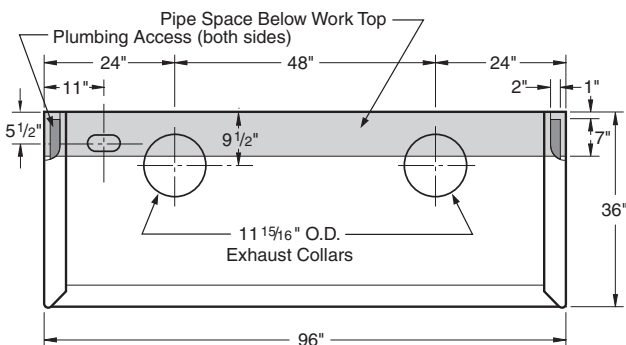

Vertical Section

