

# KEWAUNEE

**STURDIKWIK**  
**SELECTION AND ORDERING GUIDE**  
Effective May 1, 2004

---

# Table of Contents

COLOR CHART..... 3

HOW TO SELECT, SPECIFY AND ORDER..... 4

UPRIGHTS / SUPPORT LEGS..... 5

CROSS BARS..... 6

WORKSURFACES..... 7

WORKSURFACE ACCESSORIES..... 8

ESD WORKSURFACES..... 9

ESD WORKSURFACE ACCESSORIES..... 10

ESD WORKSURFACE ACCESSORIES..... 11

SHELVING SELECTION - STANDARD COLOR - DOVE GRAY..... 12

SHELVING SELECTION - NON-STANDARD COLORS..... 13

ACCESSORIES..... 14

ACCESSORIES..... 15

ACCESSORIES..... 16

STURDIKwik WARRANTY..... 17

PAINT & LAMINATE STANDARD COLOR OPTIONS		
CATEGORY	COLOR	DESIGNATOR ON ORDER
<b>Standard Worksurface Color, Laminate</b>	Almond	A
	Dove Gray	G
	Light Neutral	L
	Black	K
<b>ESD Worksurface Color, Laminate</b>	ESD Gray	EG
	ESD Almond	EA
<b>Standard Accent Strip Color, Laminate</b>	Almond	A
	Dove Gray	G
	Light Neutral	L
	Black	K
	Midori	M
	Brittany Blue	B
	Wineberry	W

<b>Standard Metal Paint Colors</b>	12 Black	20 SandTan
	61 Light Neutral	62 Driftwood
	78 Snow White	85 Satin Grey
	87 Mountain Blue	88 Malt
	89 Midori	90 Amazon
	91 Sage	92 Butter Silk
	93 Chocolate	94 True Blue
	95 Stormy Blue	96 Wineberry

Consult with your Kewaunee Sales Representative or Kewaunee Customer Service for color samples and/or leadtimes on custom colors.

Kewaunee recommends the specifications of the floor/room/area layout be determined in advance of ordering the actual workstations. The end result is a well planned, work area that meets your requirements, saves money, and provides your personnel with an ergonomically designed productive work station.

### TO BEGIN:

- (1) Measure the allocated space, making sure to accurately note door, window, electrical outlets and building column locations.
- (2) Determine personnel requirements; standing, sitting or both? Any unusual needs?
- (3) Specify features important for operational requirements, equipment being used, tools, parts, ESD requirements.

*At any time, contact a local Kewaunee sales representative or authorized Kewaunee Dealer in your area from a nationwide service network to provide you with assistance in determining your exact requirements.*

### ORDERING A STURDIKWIK BENCH:



***(IMPORTANT NOTE: Determine desired color of product first. Model numbers are color specific for column uprights and shelving.)***

- (1) Count the number of each kind of column uprights needed. (NOTE: 24"W, 30"W, 36"W bench require two (2) columns to support a worksurface. A 48"W and 60"W worksurface bay utilize either two (2) or three (3) column uprights, depending on your desire for single or dual bay configurations. The 72"W worksurface requires three (3) column uprights). Don't forget to use the center upright in dual or multiple bay configurations to take advantage of the shortened center foot. **NOTE: Do not use center uprights between spans of more than 72".**
- (2) Determine if you want Cross Bars with or without modesty panels. Order appropriate Cross Bars to attach column uprights together. In dual bay configurations, order two (2) Cross Bars that equal half the worksurface length. (For example, on a 72" dual bay workstation using a 72" worksurface, order two (2) 36"W cross bars to connect the three (3) column uprights together).
- (3) Order optional Cross Bar Wireway Trough Cap if desiring to cover trough for aesthetic purposes.
- (4) Determine type of worksurface needed. If worksurfaces are sharing a column upright with another worksurface, order the standard worksurfaces. If bench is a stand-alone bench and will be (or could be in the future) placed next to another stand-alone bench, order the extra wide worksurface to eliminate gaps at sides of bench. If ESD worksurfaces are needed, order from ESD worksurface list.
- (5) Order optional worksurface Front Apron Rail if heavy loads (in excess of 50 lbs. per linear foot of worksurface, distributed load) are expected on the worksurface. Apron Rails help prevent worksurfaces from excessive deflecting under heavy loads.
- (6) Select Shelving. Shelving units have integrated brackets which provide 90 degree, 14 degree and 22 degree tilt mounting options. If tilting shelving, be sure to order optional shelf lip.
- (7) Determine power strip requirements. Power bars can be mounted above and/or below worksurfaces.
- (8) Order other accessories as needed: Bin Bars, Task Lights, Overhead Tool Bars, Casters
- (9) Order optional anti-dislodgement clips for worksurfaces and/or shelving. All other accessories (Bin Bars, Power Bars, Task Lights and Overhead Tool Bars) come standard with anti-dislodgement clips.

### Column Uprights

- Determine color of upright and select appropriate model number. (Dove Gray is standard color).
- Use two standard uprights for a stand-alone bench.
- Use add-on upright to create multiple benches connected together, sharing columns.

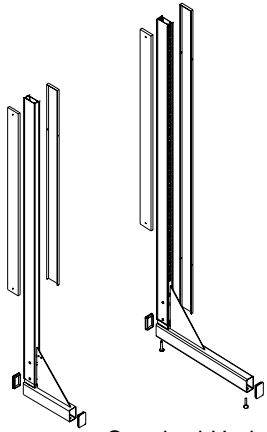
- Use center upright when desiring to create extra foot-space with the shortened foot. Do not use center uprights at end of bench. **NOTE: Do not use center uprights between spans of more than 72”.**
- Each upright is capable of supporting 500 lbs.
- Leveling glides extends up to 1”. Order casters to interchange with glides to create mobile workstations.

	Description	Model #	Ship Wgt.
	Standard Upright (Dove Gray - includes inner and end trim caps, one upright & hardware)	457700	40
	Add-On Upright (Dove Gray - includes 2 inner trim caps, one upright & hardware)	457701	40
	Center Upright (Dove Gray - includes 2 inner trim caps, center upright & hardware)	457702	39
	Non-Standard Color Upright (includes inner and end trim caps, one upright & hardware)	457740	40
	Non-Standard Color Add-On (includes 2 inner trim caps, one upright & hardware)	457741	40
	Non-Standard Color Center (includes 2 inner trim caps, center upright & hardware)	457742	39

### Column Upright Replacement Trim Caps

- Order these parts only if replacing column trim caps.

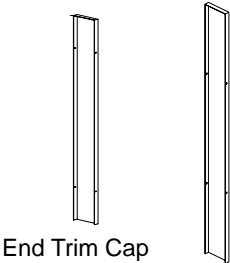
	Description	Model #	Ship Wgt.
	Inner Trim Cap for Column Upright (45 1/2”L)	457INNERCAP	4
	End Trim Cap for Column Upright (70 3/4”L)	457ENDCAP	6

### Rear Support Leg

- Order to create double-sided workstations, will NOT attach to center upright (model numbers 457702 & 457742.)

- Field installable.

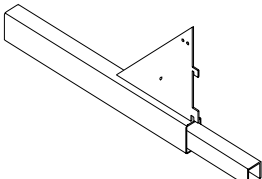
	Description	Model #	Ship Wgt.
	Double sided rear support leg (includes rear support leg & hardware)	457703	12

**Cross Bar, WITHOUT Modesty Panel**

- Attaches to column uprights. When creating multi-bay workstations, order two (2) Cross Bars equal to 1/2 the length of the worksurface.
- Must order two (2) 36"W Cross Bars to make a 72" workstation.

- Features wire/cable exit locations in bottom trough.
- Trough can be used to hold extra wire or commercially available powerstrips.
- Depth of trough is 1 3/4".

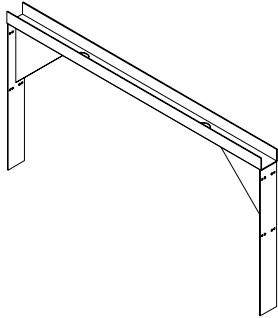

Description	Model #	Ship Wgt.
Cross Bar, 24"W	455515	19
Cross Bar, 30"W	455516	21
Cross Bar, 36"W	455517	23
Cross Bar, 48"W	455518	27
Cross Bar, 60"W	455519	32

**Cross Bar, WITH Modesty Panel**

- Attaches to column uprights. When creating multi-bay workstations, order two (2) Cross Bars equal to 1/2 the length of the worksurface.
- Must order two (2) 36"W Cross Bars to make a 72" workstation.

- Features wire/cable exit locations in bottom trough.
- Trough can be used to hold extra wire or commercially available powerstrips, depth of trough is 1 3/4".

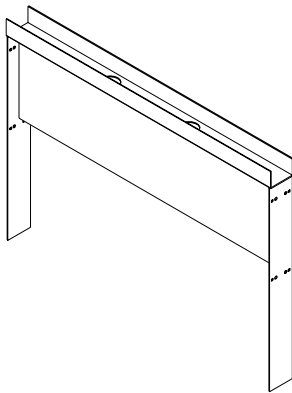

Description	Model #	Ship Wgt.
Cross Bar w/Modesty Panel, 24"W	455520	25
Cross Bar w/Modesty Panel, 30"W	455521	27
Cross Bar w/Modesty Panel, 36"W	455522	30
Cross Bar w/Modesty Panel, 48"W	455523	35
Cross Barw/Modesty Panel, 60"W	455524	40

**Cross Bar Wireway Trough Cap**

- Use to conceal cables and wires located in Cross Bar trough.
- Gravity fit.

- Cable ports at each end of cover.

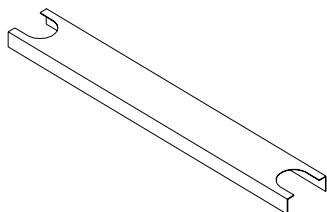

Description	Model #	Ship Wgt.
Cross Bar Wireway, 24"W	457030	7
Cross Bar Wireway, 30"W	457031	9
Cross Bar Wireway, 36"W	457032	11
Cross Bar Wireway, 48"W	457033	15
Cross Bar Wireway, 60"W	457034	18

- "Standard" Tops are designed for bench systems using common uprights. (sharing a column)
- Extra Wide is 2" wider than nominal bench size designed for single bench installations
- 48"W and wider include imbedded horizontal support on bottom side of worksurface.
- Worksurface brackets rated to hold up to 400 lbs. evenly distributed.
- Worksurface support brackets included.
- Use optional front apron rail to minimize worksurface from excessive deflection with loads exceeding 50 lbs. per linear foot.
- 72"W includes three (3) worksurface support brackets.

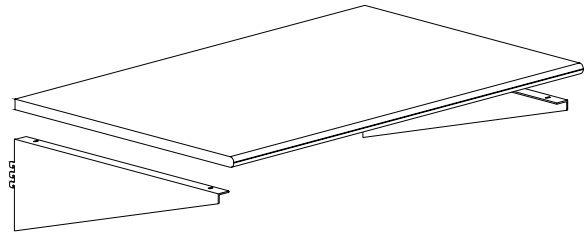

Add appropriate worksurface color designator in space on model #:  
↓

**Standard Worksurface**

Description	Model #	Ship Wgt.
<b>30" Deep</b>		
Worksurface Kit, 24"W x 30"D	457000_	32
Worksurface Kit, 30"W x 30"D	457001_	40
Worksurface Kit, 36"W x 30"D	457002_	49
Worksurface Kit, 48"W x 30"D	457003_	65
Worksurface Kit, 60"W x 30"D	457004_	81
Worksurface Kit, 72"W x 30"D	457005_	90*
<b>36" Deep</b>		
Worksurface Kit, 24"W x 36"D	457006_	39
Worksurface Kit, 30"W x 36"D	457007_	49
Worksurface Kit, 36"W x 36"D	457008_	58
Worksurface Kit, 48"W x 36"D	457009_	78
Worksurface Kit, 60"W x 36"D	457010_	97
Worksurface Kit, 72"W x 36"D	457011_	120*

\*Requires Center Column Upright #457702

**Extra Wide Worksurface**

Description	Model #	Ship Wgt.
<b>30" Deep</b>		
Worksurface Kit, 26"W x 30"D	457012_	35
Worksurface Kit, 32"W x 30"D	457013_	43
Worksurface Kit, 38"W x 30"D	457014_	51
Worksurface Kit, 50"W x 30"D	457015_	67
Worksurface Kit, 62"W x 30"D	457016_	84
Worksurface Kit, 74"W x 30"D	457017_	100*
<b>36" Deep</b>		
Worksurface Kit, 26"W x 36"D	457018_	42
Worksurface Kit, 32"W x 36"D	457019_	43
Worksurface Kit, 38"W x 36"D	457020_	62
Worksurface Kit, 50"W x 36"D	457021_	81
Worksurface Kit, 62"W x 36"D	457022_	100
Worksurface Kit, 74"W x 36"D	457023_	122*

\*Requires Center Column Upright #457702

**Front Apron Rails**

- Not required, but recommended when worksurface loads will exceed 50 lbs. per linear foot of worksurface.
- Includes hardware pack.

- Attaches under worksurface for additional horizontal worksurface support.
- Retrofittable in field.

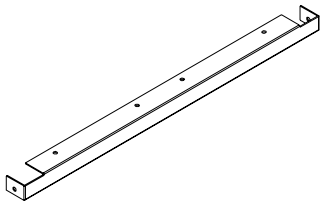

Description	Model #	Ship Wgt.
24"W, front apron rail for worksurface	455525	6
30"W, front apron rail for worksurface	455526	7
36"W, front apron rail for worksurface	455527	8
48"W, front apron rail for worksurface	455528	10
60"W, front apron rail for worksurface	455529	12
72"W, front apron rail for worksurface	455530	14

**Double Sided Worksurface Filler**

- Used to span center gap between columns when mounting worksurfaces in double sided applications, worksurfaces must be mounted at same height.

- Gravity fit.
- Rests on back edge of worksurfaces.

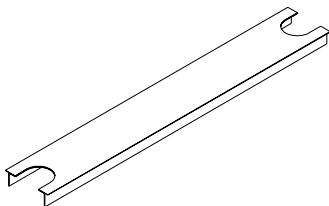

Description	Model #	Ship Wgt.
24" Double Sided Worksurface Filler	457035	8
30" Double Sided Worksurface Filler	457036	10
36" Double Sided Worksurface Filler	457037	12
48" Double Sided Worksurface Filler	457038	16
60" Double Sided Worksurface Filler	457039	19

**Corner Worksurface**

- Kit includes all necessary hardware and rear support leg.
- Specify laminate color & specify paint color.

Add appropriate worksurface color designator in space on model #:

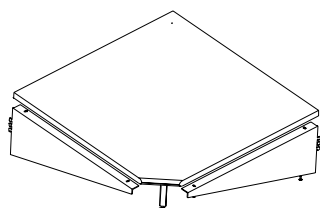

Description	Model #	Ship Wgt.
Worksurface Corner, 30"D	457024_	80
Worksurface Corner, 36"D	457025_	100

- Standard Tops are designed for bench systems using common uprights.
- Extra Wide is 2" wider than nominal bench size designed for single bench installations
- Worksurface grounding hardware included, but must be installed in field.
- High pressure static dissipative laminate top.
- Worksurface brackets rated to hold up to 400 lbs. evenly distributed.
- Worksurface support brackets included.
- Use optional front apron rail to minimize worksurface from excessive deflection with loads exceeding 50 lbs. per linear foot.

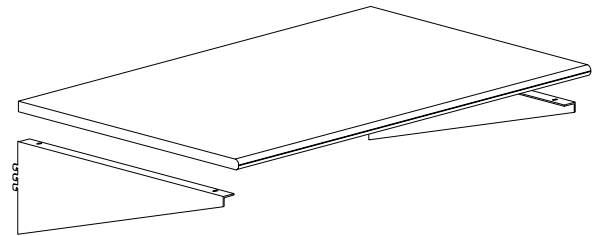

Add appropriate worksurface color designator in space on model #:  
↓

**ESD Standard Worksurface**

Description	Model #	Ship Wgt.
<b>30" Deep</b>		
Worksurface Kit, 24"W x 30"D, ESD	457000_E	32
Worksurface Kit, 30"W x 30"D, ESD	457001_E	40
Worksurface Kit, 36"W x 30"D, ESD	457002_E	49
Worksurface Kit, 48"W x 30"D, ESD	457003_E	65
Worksurface Kit, 60"W x 30"D, ESD	457004_E	81
Worksurface Kit, 72"W x 30"D, ESD	457005_E	90*
<b>36" Deep</b>		
Worksurface Kit, 24"W x 36"D, ESD	457006_E	39
Worksurface Kit, 30"W x 36"D, ESD	457007_E	49
Worksurface Kit, 36"W x 36"D, ESD	457008_E	58
Worksurface Kit, 48"W x 36"D, ESD	457009_E	78
Worksurface Kit, 60"W x 36"D, ESD	457010_E	97
Worksurface Kit, 72"W x 36"D, ESD	457011_E	120*

\*Requires Center Column Upright #457702

**ESD Extra Wide Worksurface**

Description	Model #	Ship Wgt.
<b>30" Deep</b>		
Worksurface Kit, 26"W x 30"D, ESD	457012_E	35
Worksurface Kit, 32"W x 30"D, ESD	457013_E	43
Worksurface Kit, 38"W x 30"D, ESD	457014_E	51
Worksurface Kit, 50"W x 30"D, ESD	457015_E	67
Worksurface Kit, 62"W x 30"D, ESD	457016_E	84
Worksurface Kit, 74"W x 30"D, ESD	457017_E	100*
<b>36" Deep</b>		
Worksurface Kit, 26"W x 36"D, ESD	457018_E	42
Worksurface Kit, 32"W x 36"D, ESD	457019_E	43
Worksurface Kit, 38"W x 36"D, ESD	457020_E	62
Worksurface Kit, 50"W x 36"D, ESD	457021_E	81
Worksurface Kit, 62"W x 36"D, ESD	457022_E	100
Worksurface Kit, 74"W x 36"D, ESD	457023_E	122*

\*Requires Center Column Upright #457702

**Front Apron Rails**

- Not required, but recommended when worksurface loads will exceed 50 lbs. per linear foot of worksurface.
- Includes hardware pack.

- Attaches under front edge of worksurface for additional horizontal worksurface support.
- Retrofittable in field.

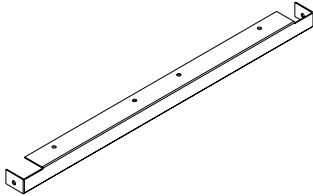

Description	Model #	Ship Wgt.
24"W, front apron rail for worksurface	455525	6
30"W, front apron rail for worksurface	455526	7
36"W, front apron rail for worksurface	455527	8
48"W, front apron rail for worksurface	455528	10
60"W, front apron rail for worksurface	455529	12
72"W, front apron rail for worksurface	455530	14

**ESD Double Sided Worksurface Filler**

- Used to span center gap between columns when mounting worksurfaces in double sided applications, worksurfaces must be mounted at same height.

- Gravity fit.
- Rests on back edge of worksurfaces.
- May also be used on back-to-back shelving mounted at same height.

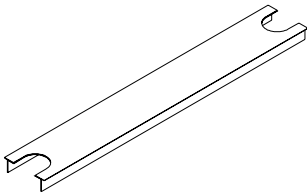

Description	Model #	Ship Wgt.
24" Double Sided Worksurface Filler	457040	8
30" Double Sided Worksurface Filler	457041	10
36" Double Sided Worksurface Filler	457042	12
48" Double Sided Worksurface Filler	457043	16
60" Double Sided Worksurface Filler	457044	19

**ESD Corner Worksurface**

- Kit includes all necessary hardware and rear support leg.

Add appropriate worksurface color designator in space on model #:  
↓

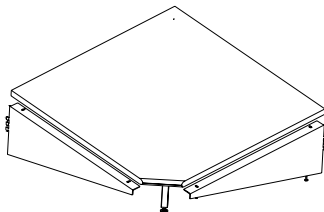

Description	Model #	Ship Wgt.
Worksurface Corner, 30"D	457024_E	80
Worksurface Corner, 36"D	457025_E	100

### Wrist Strap Grounding Kit

- Provides grounding of two wrist straps using a common point to ground.
- Measures 3" x 1 1/2" and mounts easily to the bench.

- Two (2) built-in banana jacks and 10' ground cord are included.

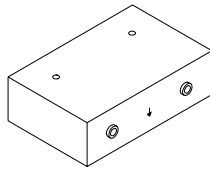

Description	Model #	Ship Wgt.
Wrist Strap Grounding Kit	990519	1

### Wrist Strap

- Insures all-around skin contact and electrical conductivity.

- 5' coiled cord included.

Description	Model #	Ship Wgt.
Wrist Strap	990517	1

### Accessory Grounding Kit

- For use with Bin Bars and Shelves.

Description	Model #	Ship Wgt.
Accessory Ground Kit	407200	1

### Drawer Grounding Kit

- For use with drawers.

Description	Model #	Ship Wgt.
Drawer Ground Kit	407201	1

### ESD Shelf Mats

- Used when a static dissipative surface on a shelf is desired.

- Grounding hardware included.

Description	Model #	Ship Wgt.
<b>12" Deep</b>		
12"D x 48"W, shelf mat	407206_	2
12"D x 60"W, shelf mat	407207_	2
12"D x 72"W, shelf mat	407208_	2
<b>18" Deep</b>		
18"D x 48"W, shelf mat	407211_	2
18"D x 60"W, shelf mat	407212_	2
18"D x 72"W, shelf mat	407213_	2

- Shelves include integrated bracket, providing 90 degree, 14 degree and 22 degree tilt mounting options.
- Order optional shelf lip if tilting shelf.
- Shelves come with perforations allowing easy addition of accessories such as shelf lips & shelf dividers.

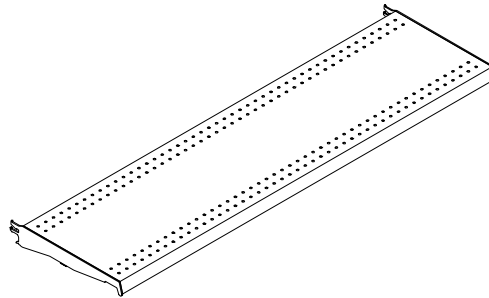

**Shelves on this page are “Standard Color” which is Dove Gray.**

**13”D, Shelf - Standard Color: Dove Gray**

Description	Model #	Ship Wgt.
Shelf, 24”W x 13”D	457050	7
Shelf, 30”W x 13”D	457051	8
Shelf, 36”W x 13”D	457052	10
Shelf, 48”W x 13”D	457053	13
Shelf, 60”W x 13”D	457054	16

**16”D, Shelf - Standard Color: Dove Gray**

Description	Model #	Ship Wgt.
Shelf, 24”W x 16”D	457055	8
Shelf, 30”W x 16”D	457056	10
Shelf, 36”W x 16”D	457057	12
Shelf, 48”W x 16”D	457058	16
Shelf, 60”W x 16”D	457059	20

**19”D, Shelf - Standard Color: Dove Gray**

Description	Model #	Ship Wgt.
Shelf, 24”W x 19”D	457060	10
Shelf, 30”W x 19”D	457061	12
Shelf, 36”W x 19”D	457062	14
Shelf, 48”W x 19”D	457063	19
Shelf, 60”W x 19”D	457064	24

- Shelves include integrated bracket, providing 90 degree, 14 degree and 22 degree tilt mounting options.
- Order optional shelf lip if tilting shelf.
- Shelves come with perforations allowing easy addition of accessories such as shelf lips & shelf dividers.

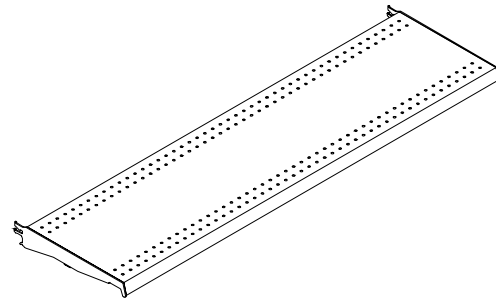

**13”D, Shelf - Non Standard Color: PAINTED**

Description	Model #	Ship Wgt.
Shelf, 24”W x 13”D	457065	7
Shelf, 30”W x 13”D	457066	8
Shelf, 36”W x 13”D	457067	10
Shelf, 48”W x 13”D	457068	13
Shelf, 60”W x 13”D	457069	16

**16”D, Shelf - Non Standard Color: PAINTED**

Description	Model #	Ship Wgt.
Shelf, 24”W x 16”D	457070	8
Shelf, 30”W x 16”D	457071	10
Shelf, 36”W x 16”D	457072	12
Shelf, 48”W x 16”D	457073	16
Shelf, 60”W x 16”D	457074	20

**19”D, Shelf - Non Standard Color: PAINTED**

Description	Model #	Ship Wgt.
Shelf, 24”W x 19”D	457075	10
Shelf, 30”W x 19”D	457076	12
Shelf, 36”W x 19”D	457077	14
Shelf, 48”W x 19”D	457078	19
Shelf, 60”W x 19”D	457079	24

**Shelf Lips**

- Attached to shelf at front or rear through existing perforations.
- Lip height is 1”.

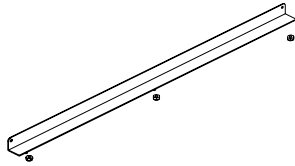

Description	Model #	Ship Wgt.
24” Lip for Shelf	457730	2
30” Lip for Shelf	457731	2
36” Lip for Shelf	457732	3
48” Lip for Shelf	457733	3
60” Lip for Shelf	457734	4

**Shelf Divider**

- Attached to shelf through existing perforations.
- Divider height is 6”.
- Hardware included.

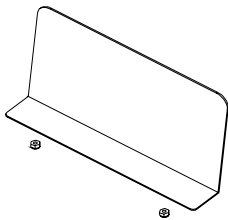

Description	Model #	Ship Wgt.
13” Divider, for 13” shelving	457735	2
16” Divider, for 16” shelving	457736	2
19” Divider, for 19” shelving	457737	3

**Anti Dislodgement Clips**

- Use on worksurface or shelf brackets to provide anti-dislodgement security.

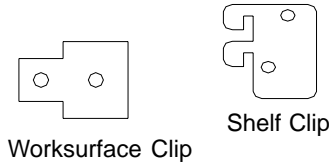

Description	Model #	Ship Wgt.
Hardware Pack, Shelf Clip, 2 per pack	401099	1
Hardware Pack, Worksurface Clip, 2 per pack	401098	1

**Foot Rails**

Description	Model #	Ship Wgt.
Foot Rail, 24”W	457750	5
Foot Rail, 30”W	457751	6
Foot Rail, 36”W	457752	8
Foot Rail, 48”W	457753	10
Foot Rail, 60”W	457754	15

**3” Casters**

- Casters swivel 360 degrees.
- Replaces leveling glide in leg to create mobile workstations.

**CAUTION:** Do not use casters on 36” worksurface units. Order appropriate anti-dislodgement clips (pg. 20) for worksurfaces and shelving when using casters.

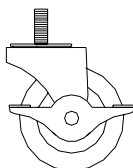

Description	Model #	Ship Wgt.
3”, Swivel, 210lb., Black (Single)	990639	1
3”, Swivel w/ Brake, 210lb., Black (Single)	990527	1

**Task Lights**

- Includes support brackets and flourescent bulbs.
- 8' long cord with standard 3-prong grounded plug.

- Includes anti-dislodgement clips.
- Task Light bracket can also accomodate overhead tool bar.

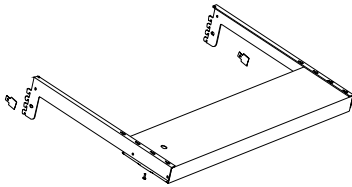

Description	Model #	Ship Wgt.
Task Light, 30", w/ Brackets	457712	17
Task Light, 36", w/ Brackets	457713	20
Task Light, 48", w/ Brackets	457714	27
Task Light, 60", w/ Brackets	457715	34
Task Light, 72", w/ Brackets	457760	42

**Overhead Tool Bar - Must order Tool Bar Bracket Set (below) if used WITHOUT Task Light**

- Includes trolley.
- Tool bar balancer not included.

- Specify Color.

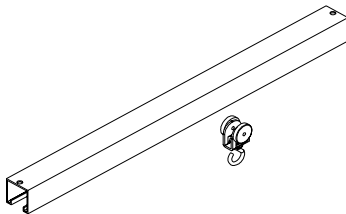

Description	Model #	Ship Wgt.
Tool Bar, 24"	457716	4
Tool Bar, 30"	457717	4
Tool Bar, 36"	457718	5
Tool Bar, 48"	457719	5
Tool Bar, 60"	457720	6
Tool Bar, 72"	457765	7

**Tool Bar Bracket Set - Must order if only using a Tool Bar and NO Light**

- Includes anti-dislodgement clips.

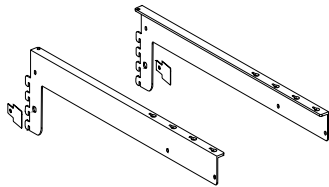

Description	Model #	Ship Wgt.
Bracket Set	457710	7

**Tool Bar Trolley - Order if needing extra trolleys in overhead tool bar**



Description	Model #	Ship Wgt.
Tool Bar Trolley	407115	1

**Tool Balancer - Hangs off of trolley to suspend tools**

Description	Model #	Ship Wgt.
Tool Balancer	457080	3

**Power Bar**

- All power bars have 9' cord with standard 3-prong grounded plug.
- 15 amp circuit breaker built into unit.

- Includes anti-dislodgement clips.
- Six (6) 15-amp receptacles in each power bar.
- On a dual bay 72" workstation use two (2) 36" power bars.

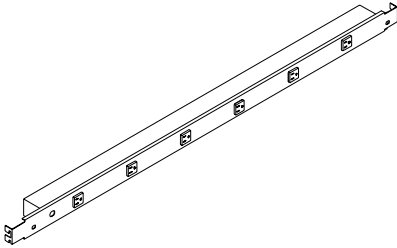

Description	Model #	Ship Wgt.
24"-15AMP, 6-outlet Power Bar	457705	10
30"-15AMP, 6-outlet Power Bar	457706	10
36"-15AMP, 6-outlet Power Bar	457707	12
48"-15AMP, 6-outlet Power Bar	457708	14
60"-15AMP, 6-outlet Power Bar	457709	16

**Bin Bar**

- Holds standard parts bins.
- Includes anti-dislodgement clips.

- Bins ordered sperately.

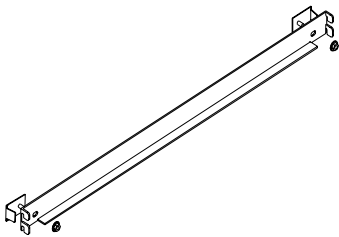

Description	Model #	Ship Wgt.
Bin Bar, 24"	457721	2
Bin Bar, 30"	457722	3
Bin Bar, 36"	457723	3
Bin Bar, 48"	457724	3
Bin Bar, 60"	457725	4

**Bins**

- Only one color per carton may be ordered.

Add appropriate color designator in space on model #: Y=Yellow, B=Blue, R=Red  
↓

Description	Model #	Ship Wgt.
<b>Standard Parts Bins</b>		
4 3/4"L x 3 1/2"W x 2 1/2"H, 24 per carton	ACC30210_	10
6 3/4"L x 3 1/2"W x 2 7/8"H, 24 per carton	ACC30220_	10
10 1/4"L x 4 3/8"W x 4 3/4"H, 12 per carton	ACC30230_	10
14"L x 14 3/4"W x 6 3/4"H, 6 per carton	ACC30240_	10
<b>ESD Parts Bins - BLACK ONLY</b>		
4"L x 3 1/2"W x 2 1/2"H, 1 per carton	ACC4452	1
6"L x 3 3/8"W x 2 1/2"H, 1 per carton	ACC4453	1
9"L x 4 3/8"W x 4 3/8"H, 1 per carton	ACC4454	1

Kewaunee Scientific Corporation Technical Furniture Group warrants Kewaunee SturdiKwik branded products, manufactured by the Technical Furniture Group, to be free from defects in materials and workmanship (normal wear and tear excepted), for one (1) year, to the original purchaser of the product, except as provided below. Kewaunee Scientific Corporation, at its option, will repair or replace with comparable product, free of charge, any product, part, or component of the SturdiKwik branded product manufactured after October 1, 2001, which fails under normal use as a result of such defect.

Natural variation occurring in wood or other materials will not be considered defects; and Kewaunee Scientific Corporation does not warrant the color-fastness or matching of colors, grains, or textures of such materials. This warranty does not apply to: damage caused by the carrier; modifications of the product; attachments to the product not approved by Kewaunee Scientific Corporation; non-standard materials selected by and used at the request of a user; and products that were not installed, used or maintained in accordance with product instructions and warnings. To the extent seating products are used in the manner that exceed the equivalent of a single forty (40) hour work week, the applicable warranty period will be reduced in a pro-rata manner.

This warranty has the following exceptions: lamps and ballasts are not warranted; high-wear parts such as glides, drawer slides, pneumatic cylinders, casters, polymer-based components, user-adjustable worksurface mechanisms are warranted for 90-days from the date of sale; Worksurfaces purchased and used without front apron rails or frames are not warranted for deflection or sagging.

THERE ARE NO IMPLIED WARRANTIES OF MERCHANTABILITY OR FITNESS FOR PARTICULAR PURPOSE.

Kewaunee Scientific Corporation's sole obligation and the user's exclusive remedy under this warranty shall be limited to the repair or replacement, at Kewaunee Scientific Corporation's sole discretion and cost, of products or components. In no event shall Kewaunee Scientific Corporation be responsible for consequential or incidental damages arising out of a claim of defective product.

To obtain service under this warranty:

1. Contact the dealer or agent from whom the product was purchased within 30 days of discovery of the defect. You must provide a reasonable opportunity for inspection and investigation of claim, prior to any repairs or alterations to the product.
2. The dealer or agent will gather all pertinent information regarding the claim, including proof of purchase (copy of purchaser's invoice or purchasing receipt) and correct model from defective product and contact a Customer Service representative to ensure product is under warranty.
3. If under warranty, the Customer Service representative of other Company representative will decide whether to provide replacement parts to repair the product or replace the product.
4. Consent of Kewaunee Scientific Corporation must be obtained before any warranty work is performed.

This warranty does not cover ordinary maintenance, wear and tear, abuse, improper use (including repairs or attempted repairs other than by Kewaunee Scientific Corporation or its authorized representative). This warranty covers the original purchase of new product used for normal commercial use only when installed and used as specified and does not apply to product used for personal or household use, or product used for rental purposes.



P.O. Box 1842  
Statesville, NC 28687  
800-824-6626 - phone  
800-624-5536 - fax  
marketing-tfg@kewaunee.com