

Alpha System Carts

Features:

- The adaptability of the Alpha System and the convenience of mobility
 - Standard double-slotted uprights mounted on heavy gauge steel frame
 - Available with large diameter, heavy duty casters or glides
 - Available with or without overhead carrier
 - Available in all standard module lengths – from 24" to 72"
- Accepts standard Alpha System components including:
- Adjustable Height Cantilevered Worksurface Frames
 - for supporting Worksurface Top and Suspended Base Cabinets
 - easily positioned on 1" increments
 - Adjustable Module Shelving
 - available in five depths
 - available in steel, wood, and phenolic resin
 - available with or without retaining lips
 - adjustable on 1" increments

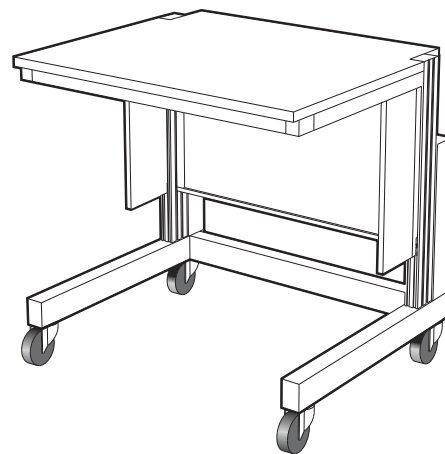
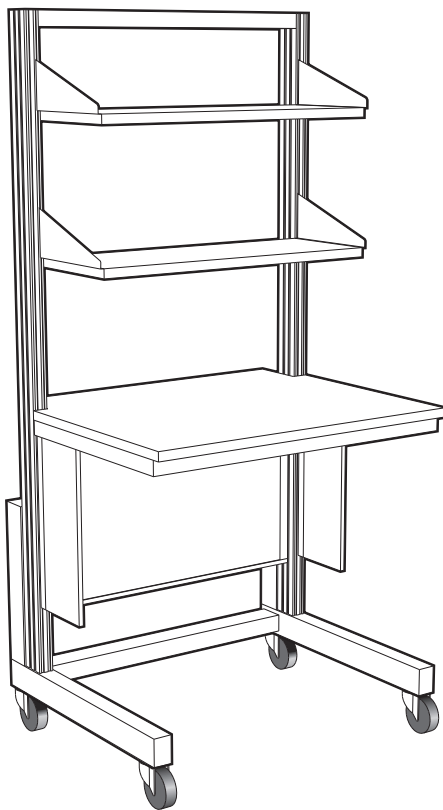

Select Alpha System Cart frame components and Worksurface Tops from the following two pages. Select Adjustable Module Shelves from pages 51-56

Cantilevered Worksurface Frames from pages 58 and 59, suspended base cabinets from pages 100 through 108 and suspended upper cabinets from pages 136 through 141.

Alpha System Carts

Specifications:

Alpha System Carts incorporate the same double slotted uprights used in the Alpha System Structural Modules. The uprights are mounted to a base fabricated of steel tubing and mounted on 4" diameter casters or glides. This creates a mobile system designed to support both the same Cantilevered Worksurface Frames and Adjustable Shelves used on the Structural Support Modules.

The Alpha System Cart is 37" high, with Upper Carrier 78" high. Both are 30" deep and available in lengths shown.

Worksurface Frame, Top and Adjustable Shelves must be ordered separately.

Alpha System Cart

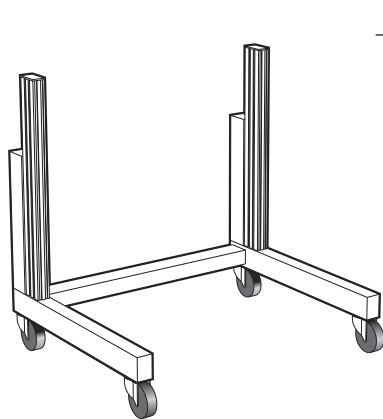

Length	with Caster	with Glides
24"	F57-3724-0C	F57-3724-0G
30"	F57-3730-0C	F57-3730-0G
36"	F57-3736-0C	F57-3736-0G
42"	F57-3742-0C	F57-3742-0G
48"	F57-3748-0C	F57-3748-0G
54"	F57-3754-0C	F57-3754-0G
60"	F57-3760-0C	F57-3760-0G
66"	F57-3766-0C	F57-3766-0G
72"	F57-3772-0C	F57-3772-0G

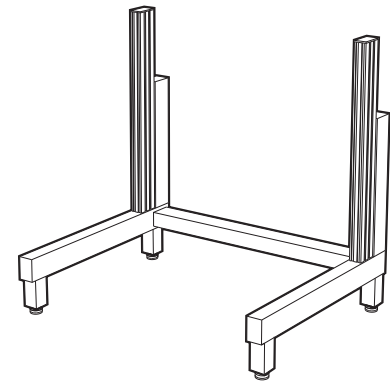

Alpha System Cart with Upper Carrier

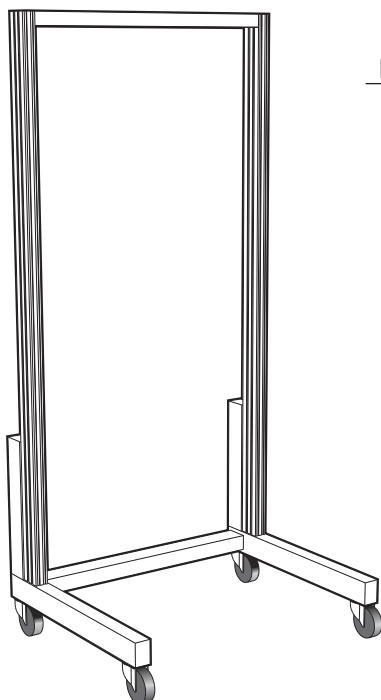

Length	with Casters	with Glides
24"	F57-7824-0C	F57-7824-0G
30"	F57-7830-0C	F57-7830-0G
36"	F57-7836-0C	F57-7836-0G
42"	F57-7842-0C	F57-7842-0G
48"	F57-7848-0C	F57-7848-0G
54"	F57-7854-0C	F57-7854-0G
60"	F57-7860-0C	F57-7860-0G
66"	F57-7866-0C	F57-7866-0G
72"	F57-7872-0C	F57-7872-0G

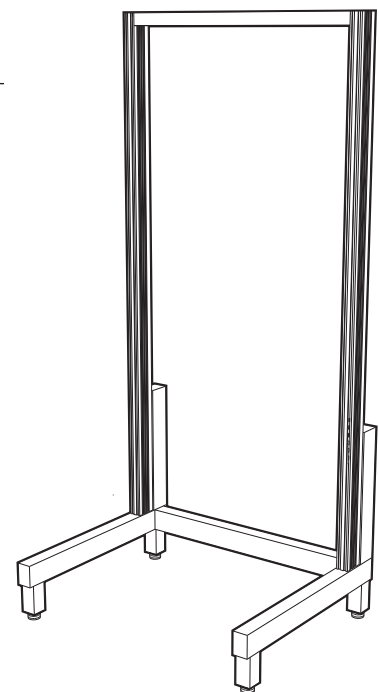

Alpha System Carts

Specifications:

Alpha System Cart Worksurface Tops are available in modular sizes to match the length and depth of the Worksurface Frames. Worksurface Tops are 1" thick. Front edges are treated as shown on page 69. All other edges are finished square.

Electrical Service Strip & Modesty Panel for Alpha System Cart

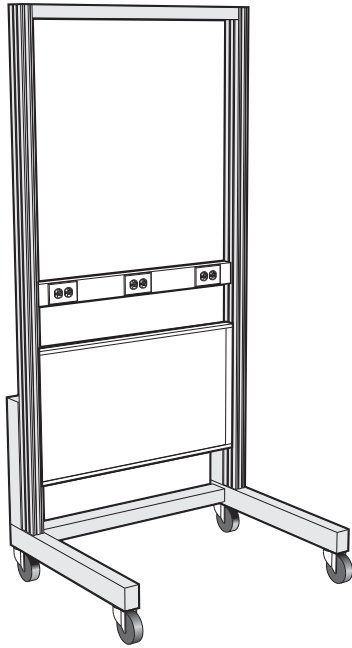

Length	Electrical Service Strip	Duplex Outlets
24"	F56M0324-00	2
30"	F56M0330-00	2
36"	F56M0336-00	3
42"	F56M0342-00	3
48"	F56M0348-00	3
54"	F56M0354-00	3
60"	F56M0360-00	3
66"	F56M0366-00	3
72"	F56M0372-00	3

Length	Modesty Panel
24"	F57M1924-00
30"	F57M1930-00
36"	F57M1936-00
42"	F57M1942-00
48"	F57M1948-00
54"	F57M1954-00
60"	F57M1960-00
66"	F57M1966-00
72"	F57M1972-00

Alpha System Cart Worksurface

see page 58-59 for Worksurface Frames

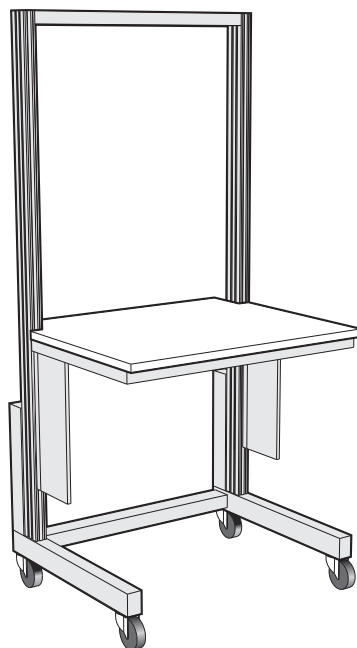

	Length	Black Kemresin®	Phenolic Resin	High Pressure Laminate
24" TOP for 23" deep frames	24"	F58R3024-00	F58T3024-00	F58P3024-00
	30"	F58R3030-00	F58T3030-00	F58P3030-00
	36"	F58R3036-00	F58T3036-00	F58P3036-00
	42"	F58R3042-00	F58T3042-00	F58P3042-00
	48"	F58R3048-00	F58T3048-00	F58P3048-00
	54"	F58R3054-00	F58T3054-00	F58P3054-00
	60"	F58R3060-00	F58T3060-00	F58P3060-00
	66"	F58R3066-00	F58T3066-00	F58P3066-00
72"	F58R3072-00	F58T3072-00	F58P3072-00	

	Length	Black Kemresin®	Phenolic Resin	High Pressure Laminate
30" TOP for 29" deep frames	24"	F58R3624-00	F58T3624-00	F58P3624-00
	30"	F58R3630-00	F58T3630-00	F58P3630-00
	36"	F58R3636-00	F58T3636-00	F58P3636-00
	42"	F58R3642-00	F58T3642-00	F58P3642-00
	48"	F58R3648-00	F58T3648-00	F58P3648-00
	54"	F58R3654-00	F58T3654-00	F58P3654-00
	60"	F58R3660-00	F58T3660-00	F58P3660-00
	66"	F58R3666-00	F58T3666-00	F58P3666-00
72"	F58R3672-00	F58T3672-00	F58P3672-00	

see page 58-59 for Worksurface Frames

Heavy Duty Alpha System Cart

Heavy Duty Alpha System Cart Assembly

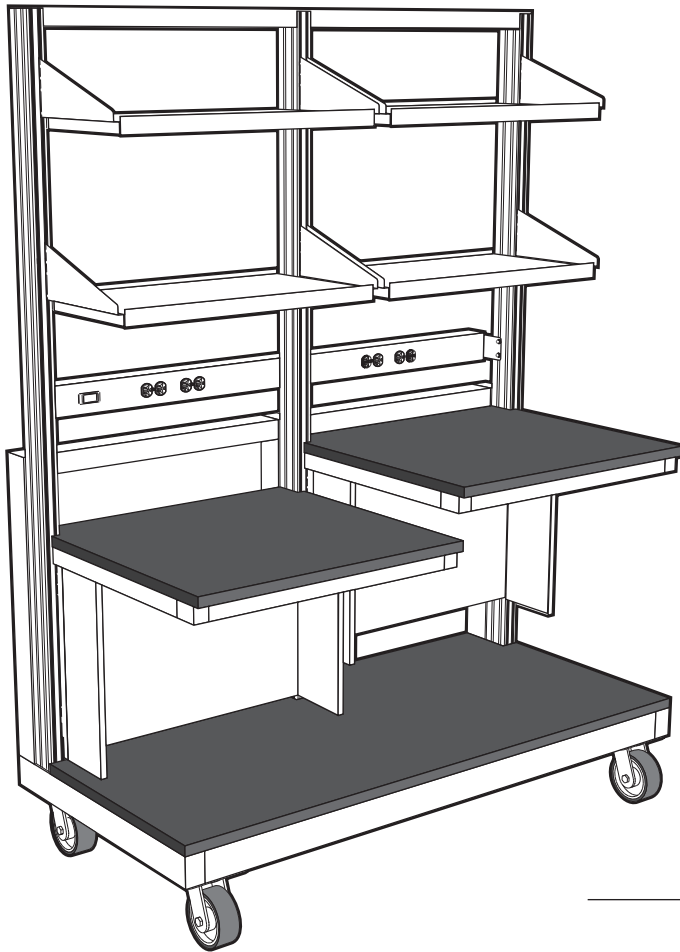

Features:

- 3000 pound load capacity
- Two adjustable height, half-length, black Kemresin Worktops with locking frames
- Worktops individually adjustable on 1" centers from 33" to 40"
- Four 15" deep, half-length, adjustable height, steel locking shelves with retaining lips on front and rear
- Shelves adjustable on 1" centers
- One 24" deep fixed, Kemresin shelf at base of bench
- One switched, adjustable height, power strip with four duplex receptacles and 10 foot pigtail
- Four heavy duty casters, with locking brakes on front casters
- Overall dimensions: 30" deep x 79½" high

Heavy Duty Alpha System Cart Assembly

Length

48"	F98-2448-00
60"	F98-2460-00
72"	F98-2472-00